



**SECTION A. Table of Contents****Section A. Facility/Source Identification**

Table of Contents  
Site Inventory List

**Section B. General Title V Requirements**

- #001 Definitions
- #002 Prohibition of Air Pollution
- #003 Property Rights
- #004 Permit Expiration
- #005 Permit Renewal
- #006 Transfer of Ownership or Operational Control
- #007 Inspection and Entry
- #008 Compliance Requirements
- #009 Need to Halt or Reduce Activity Not a Defense
- #010 Duty to Provide Information
- #011 Reopening and Revising the Title V Permit for Cause
- #012 Reopening a Title V Permit for Cause by EPA
- #013 Operating Permit Application Review by the EPA
- #014 Significant Operating Permit Modifications
- #015 Minor Operating Permit Modifications
- #016 Administrative Operating Permit Amendments
- #017 Severability Clause
- #018 Fee Payment
- #019 Authorization for De Minimis Emission Increases
- #020 Reactivation of Sources
- #021 Circumvention
- #022 Submissions
- #023 Sampling, Testing and Monitoring Procedures
- #024 Recordkeeping Requirements
- #025 Reporting Requirements
- #026 Compliance Certification
- #027 Operational Flexibility
- #028 Risk Management
- #029 Approved Economic Incentives and Emission Trading Programs
- #030 Permit Shield
- #031 Reporting
- #032 Report Format

**Section C. Site Level Title V Requirements**

- C-I: Restrictions
- C-II: Testing Requirements
- C-III: Monitoring Requirements
- C-IV: Recordkeeping Requirements
- C-V: Reporting Requirements
- C-VI: Work Practice Standards
- C-VII: Additional Requirements
- C-VIII: Compliance Certification
- C-IX: Compliance Schedule

**Section D. Source Level Title V Requirements**

- D-I: Restrictions
- D-II: Testing Requirements
- D-III: Monitoring Requirements
- D-IV: Recordkeeping Requirements
- D-V: Reporting Requirements



## SECTION A. Table of Contents

D-VI: Work Practice Standards  
D-VII: Additional Requirements

Note: These same sub-sections are repeated for each source!

### Section E. Source Group Restrictions

E-I: Restrictions  
E-II: Testing Requirements  
E-III: Monitoring Requirements  
E-IV: Recordkeeping Requirements  
E-V: Reporting Requirements  
E-VI: Work Practice Standards  
E-VII: Additional Requirements

### Section F. Alternative Operating Scenario(s)

F-I: Restrictions  
F-II: Testing Requirements  
F-III: Monitoring Requirements  
F-IV: Recordkeeping Requirements  
F-V: Reporting Requirements  
F-VI: Work Practice Standards  
F-VII: Additional Requirements

### Section G. Emission Restriction Summary

### Section H. Miscellaneous

**SECTION A. Site Inventory List**

Source ID	Source Name	Capacity/Throughput		Fuel/Material
001	MW COMBUSTOR 1	33,333.000	Lbs/HR	MUNIC./RESIDUAL/SEWA
		25,740.000	CF/HR	PROPANE
002	MW COMBUSTOR 2	33,333.000	Lbs/HR	MUNIC./RESIDUAL/SEWA
		25,740.000	CF/HR	PROPANE
003	MW COMBUSTOR 3	33,333.000	Lbs/HR	MUNIC./RESIDUAL/SEWA
		25,740.000	CF/HR	PROPANE
004	HYDRATED LIME SILO			
005	PEBBLE LIME SILO			
006	FIRE PUMP DIESEL ENGINE	5.000	Gal/HR	DIESEL FUEL
007	PAVED ROAD			
008	ACTIVATED CARBON STORAGE SILO			
009	EMERGENCY GENERATOR	7.200	Gal/HR	Propane
010	COOLING TOWER			
C01	FURNACE DRY LIME INJECTION SYSTEM			
C01A1	LN TECHNOLOGY			
C01A2	SELECTIVE NON-CATALYTIC REDUCTION			
C01B	ACTIVATED CARBON SYSTEM			
C01C	JOY ENVIR. DRY SCRUBBER			
C01D	JOY ENVIR. BAGHOUSE			
C02	FURNACE DRY LIME INJECTION SYSTEM			
C02A1	LN TECHNOLOGY			
C02A2	SELECTIVE NON-CATALYTIC REDUCTION			
C02B	ACTIVATED CARBON SYSTEM			
C02C	JOY ENVIR. DRY SCRUBBER			
C02D	JOY ENVIR. BAGHOUSE			
C03	FURNACE DRY LIME INJECTION SYSTEM			
C03A1	LN TECHNOLOGY			
C03A2	SELECTIVE NON-CATALYTIC REDUCTION			
C03B	ACTIVATED CARBON SYSTEM			
C03C	JOY ENVIR. DRY SCRUBBER			
C03D	JOY ENVIR. BAGHOUSE			
C04	BAGHOUSE - HYDRATED LIME SILO			
C05	BAGHOUSE - PEBBLE LIME SILO			
C06	BAGHOUSE - ACTIVATED CARBON STORAGE SILO			
FM001	PROPANE TANKS (2)			
FM002	MSW/RESIDUAL/SEWAGE SLUDGE			
FM003	DIESEL STORAGE TANK			
S01	COMBUSTOR 1 EXHAUST STACK			
S02	COMBUSTOR 2 EXHAUST STACK			
S03	COMBUSTOR 3 EXHAUST STACK			

**SECTION A. Site Inventory List**

Source ID	Source Name	Capacity/Throughput	Fuel/Material
S04	HYDRATED LIME SILO EXHAUST STACK		
S05	PEBBLE LIME SILO EXHAUST STACK		
S06	FIRE PUMP STACK		
S08	ACTIVATED CARBON SILO VENT		
S09	EMERGENCY GENERATOR		
Z07	FUGITIVE EMISSIONS - PAVED ROADS		
Z10	FUGITIVE EMISSIONS - COOLING TOWER		

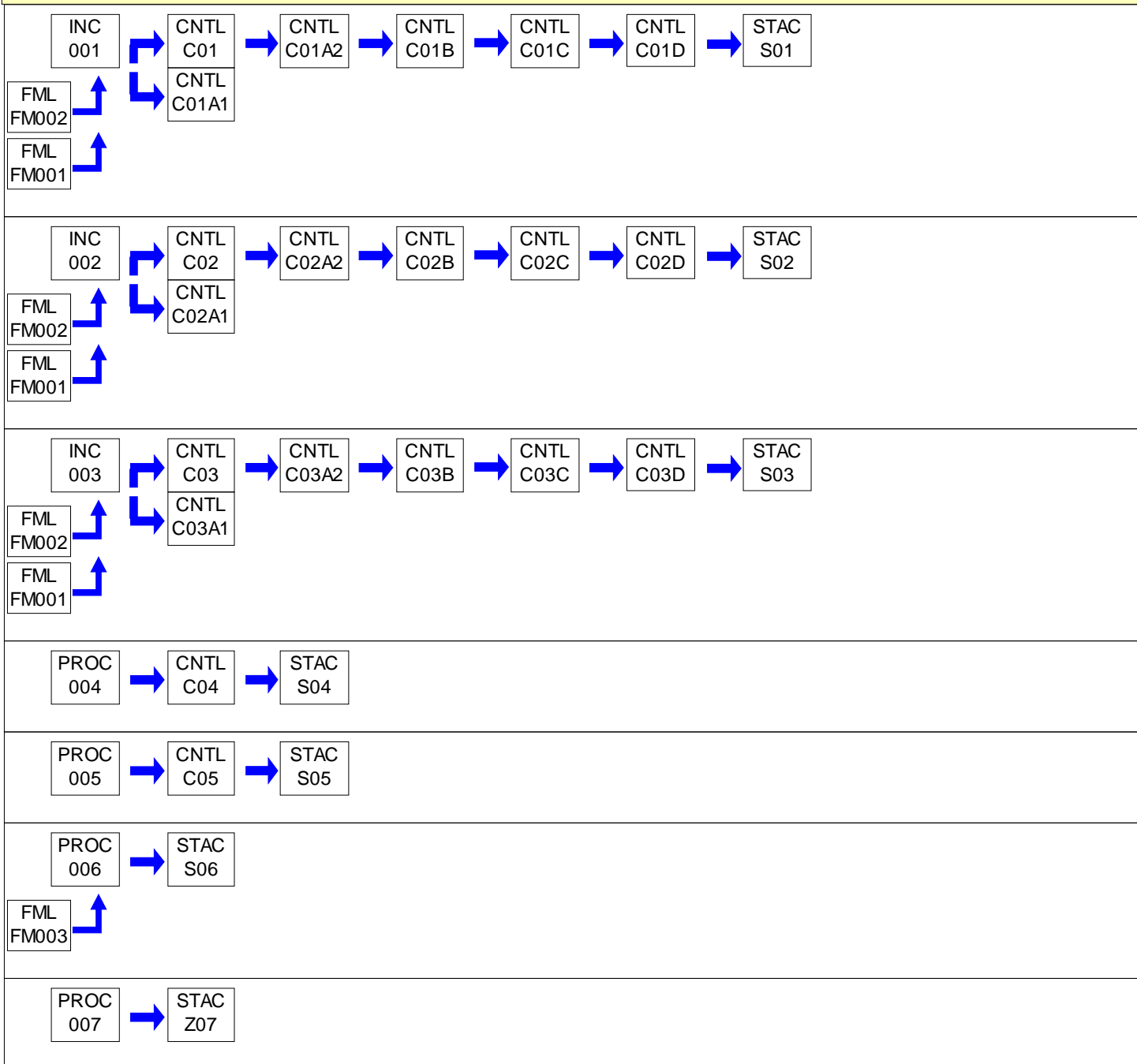
**PERMIT MAPS**



**PERMIT MAPS**

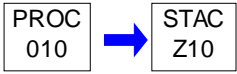
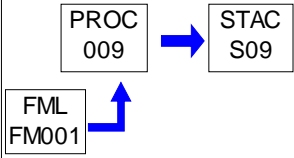
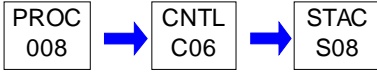

**SECTION B. General Title V Requirements****#001 [25 Pa. Code § 121.1]****Definitions**

Words and terms that are not otherwise defined in this permit shall have the meanings set forth in Section 3 of the Air Pollution Control Act (35 P.S. § 4003) and 25 Pa. Code § 121.1.

**#002 [25 Pa. Code § 121.7]****Prohibition of Air Pollution**

No person may permit air pollution as that term is defined in the act.

**#003 [25 Pa. Code § 127.512(c)(4)]****Property Rights**

This permit does not convey property rights of any sort, or any exclusive privileges.

**#004 [25 Pa. Code § 127.446(a) and (c)]****Permit Expiration**

This operating permit is issued for a fixed term of five (5) years and shall expire on the date specified on Page 1 of this permit. The terms and conditions of the expired permit shall automatically continue pending issuance of a new Title V permit, provided the permittee has submitted a timely and complete application and paid applicable fees required under 25 Pa. Code Chapter 127, Subchapter I and the Department is unable, through no fault of the permittee, to issue or deny a new permit before the expiration of the previous permit. An application is complete if it contains sufficient information to begin processing the application, has the applicable sections completed and has been signed by a responsible official.

**#005 [25 Pa. Code §§ 127.412, 127.413, 127.414, 127.446(e), 127.503 & 127.704(b)]****Permit Renewal**

(a) An application for the renewal of the Title V permit shall be submitted to the Department at least six (6) months, and not more than 18 months, before the expiration date of this permit. The renewal application is timely if a complete application is submitted to the Department's Regional Air Manager within the timeframe specified in this permit condition.

(b) The application for permit renewal shall include the current permit number, the appropriate permit renewal fee, a description of any permit revisions and off-permit changes that occurred during the permit term, and any applicable requirements that were promulgated and not incorporated into the permit during the permit term. The fees shall be made payable to "The Commonwealth of Pennsylvania Clean Air Fund" and submitted with the fee form to the respective regional office.

(c) The renewal application shall also include submission of proof that the local municipality and county, in which the facility is located, have been notified in accordance with 25 Pa. Code § 127.413. The application for renewal of the Title V permit shall also include submission of compliance review forms which have been used by the permittee to update information submitted in accordance with either 25 Pa. Code § 127.412(b) or § 127.412(j).

(d) The permittee, upon becoming aware that any relevant facts were omitted or incorrect information was submitted in the permit application, shall promptly submit such supplementary facts or corrected information during the permit renewal process. The permittee shall also promptly provide additional information as necessary to address any requirements that become applicable to the source after the date a complete renewal application was submitted but prior to release of a draft permit.

**#006 [25 Pa. Code §§ 127.450(a)(4) & 127.464(a)]****Transfer of Ownership or Operational Control**

(a) In accordance with 25 Pa. Code § 127.450(a)(4), a change in ownership or operational control of the source shall be treated as an administrative amendment if:

(1) The Department determines that no other change in the permit is necessary;

(2) A written agreement has been submitted to the Department identifying the specific date of the transfer of permit responsibility, coverage and liability between the current and the new permittee; and,

(3) A compliance review form has been submitted to the Department and the permit transfer has been approved by

**SECTION B. General Title V Requirements**

the Department.

(b) In accordance with 25 Pa. Code § 127.464(a), this permit may not be transferred to another person except in cases of transfer-of-ownership which are documented and approved to the satisfaction of the Department.

**#007 [25 Pa. Code § 127.513, 35 P.S. § 4008 and § 114 of the CAA]****Inspection and Entry**

(a) Upon presentation of credentials and other documents as may be required by law for inspection and entry purposes, the permittee shall allow the Department of Environmental Protection or authorized representatives of the Department to perform the following:

- (1) Enter at reasonable times upon the permittee's premises where a Title V source is located or emissions related activity is conducted, or where records are kept under the conditions of this permit;
- (2) Have access to and copy or remove, at reasonable times, records that are kept under the conditions of this permit;
- (3) Inspect at reasonable times, facilities, equipment including monitoring and air pollution control equipment, practices, or operations regulated or required under this permit;
- (4) Sample or monitor, at reasonable times, substances or parameters, for the purpose of assuring compliance with the permit or applicable requirements as authorized by the Clean Air Act, the Air Pollution Control Act, or the regulations promulgated under the Acts.

(b) Pursuant to 35 P.S. § 4008, no person shall hinder, obstruct, prevent or interfere with the Department or its personnel in the performance of any duty authorized under the Air Pollution Control Act.

(c) Nothing in this permit condition shall limit the ability of the EPA to inspect or enter the premises of the permittee in accordance with Section 114 or other applicable provisions of the Clean Air Act.

**#008 [25 Pa. Code §§ 127.25, 127.444, & 127.512(c)(1)]****Compliance Requirements**

(a) The permittee shall comply with the conditions of this permit. Noncompliance with this permit constitutes a violation of the Clean Air Act and the Air Pollution Control Act and is grounds for one (1) or more of the following:

- (1) Enforcement action
- (2) Permit termination, revocation and reissuance or modification
- (3) Denial of a permit renewal application

(b) A person may not cause or permit the operation of a source, which is subject to 25 Pa. Code Article III, unless the source(s) and air cleaning devices identified in the application for the plan approval and operating permit and the plan approval issued to the source are operated and maintained in accordance with specifications in the applications and the conditions in the plan approval and operating permit issued by the Department. A person may not cause or permit the operation of an air contamination source subject to 25 Pa. Code Chapter 127 in a manner inconsistent with good operating practices.

(c) For purposes of Sub-condition (b) of this permit condition, the specifications in applications for plan approvals and operating permits are the physical configurations and engineering design details which the Department determines are essential for the permittee's compliance with the applicable requirements in this Title V permit.

**#009 [25 Pa. Code § 127.512(c)(2)]****Need to Halt or Reduce Activity Not a Defense**

It shall not be a defense for a permittee in an enforcement action that it would have been necessary to halt or reduce the permitted activity in order to maintain compliance with the conditions of this permit.



**SECTION B. General Title V Requirements****#010 [25 Pa. Code §§ 127.411(d) & 127.512(c)(5)]****Duty to Provide Information**

(a) The permittee shall furnish to the Department, within a reasonable time, information that the Department may request in writing to determine whether cause exists for modifying, revoking and reissuing, or terminating the permit, or to determine compliance with the permit.

(b) Upon request, the permittee shall also furnish to the Department copies of records that the permittee is required to keep by this permit, or for information claimed to be confidential, the permittee may furnish such records directly to the Administrator of EPA along with a claim of confidentiality.

**#011 [25 Pa. Code §§ 127.463, 127.512(c)(3) & 127.542]****Reopening and Revising the Title V Permit for Cause**

(a) This Title V permit may be modified, revoked, reopened and reissued or terminated for cause. The filing of a request by the permittee for a permit modification, revocation and reissuance, or termination, or of a notification of planned changes or anticipated noncompliance does not stay a permit condition.

(b) This permit may be reopened, revised and reissued prior to expiration of the permit under one or more of the following circumstances:

(1) Additional applicable requirements under the Clean Air Act or the Air Pollution Control Act become applicable to a Title V facility with a remaining permit term of three (3) or more years prior to the expiration date of this permit. The Department will revise the permit as expeditiously as practicable but not later than 18 months after promulgation of the applicable standards or regulations. No such revision is required if the effective date of the requirement is later than the expiration date of this permit, unless the original permit or its terms and conditions has been extended.

(2) Additional requirements, including excess emissions requirements, become applicable to an affected source under the acid rain program. Upon approval by the Administrator of EPA, excess emissions offset plans for an affected source shall be incorporated into the permit.

(3) The Department or the EPA determines that this permit contains a material mistake or inaccurate statements were made in establishing the emissions standards or other terms or conditions of this permit.

(4) The Department or the Administrator of EPA determines that the permit must be revised or revoked to assure compliance with the applicable requirements.

(c) Proceedings to revise this permit shall follow the same procedures which apply to initial permit issuance and shall affect only those parts of this permit for which cause to revise exists. The revision shall be made as expeditiously as practicable.

(d) Regardless of whether a revision is made in accordance with (b)(1) above, the permittee shall meet the applicable standards or regulations promulgated under the Clean Air Act within the time frame required by standards or regulations.

**#012 [25 Pa. Code § 127.543]****Reopening a Title V Permit for Cause by EPA**

As required by the Clean Air Act and regulations adopted thereunder, this permit may be modified, reopened and reissued, revoked or terminated for cause by EPA in accordance with procedures specified in 25 Pa. Code § 127.543.

**#013 [25 Pa. Code § 127.522(a)]****Operating Permit Application Review by the EPA**

The applicant may be required by the Department to provide a copy of the permit application, including the compliance plan, directly to the Administrator of the EPA. Copies of title V permit applications to EPA, pursuant to 25 PA Code §127.522(a), shall be submitted, if required, to the following EPA e-mail box:

R3\_Air\_Apps\_and\_Notices@epa.gov

Please place the following in the subject line: TV [permit number], [Facility Name].

**SECTION B. General Title V Requirements****#014 [25 Pa. Code § 127.541]****Significant Operating Permit Modifications**

When permit modifications during the term of this permit do not qualify as minor permit modifications or administrative amendments, the permittee shall submit an application for significant Title V permit modifications in accordance with 25 Pa. Code § 127.541. Notifications to EPA, pursuant to 25 PA Code §127.522(a), if required, shall be submitted, to the following EPA e-mail box:

R3\_Air\_Apps\_and\_Notices@epa.gov

Please place the following in the subject line: TV [permit number], [Facility Name].

**#015 [25 Pa. Code §§ 121.1 & 127.462]****Minor Operating Permit Modifications**

The permittee may make minor operating permit modifications (as defined in 25 Pa. Code §121.1), on an expedited basis, in accordance with 25 Pa. Code §127.462 (relating to minor operating permit modifications). Notifications to EPA, pursuant to 25 PA Code §127.462(c), if required, shall be submitted, to the following EPA e-mail box:

R3\_Air\_Apps\_and\_Notices@epa.gov

Please place the following in the subject line: TV [permit number], [Facility Name].

**#016 [25 Pa. Code § 127.450]****Administrative Operating Permit Amendments**

(a) The permittee may request administrative operating permit amendments, as defined in 25 Pa. Code §127.450(a). Copies of request for administrative permit amendment to EPA, pursuant to 25 PA Code §127.450(c)(1), if required, shall be submitted to the following EPA e-mail box:

R3\_Air\_Apps\_and\_Notices@epa.gov

Please place the following in the subject line: TV [permit number], [Facility Name].

(b) Upon final action by the Department granting a request for an administrative operating permit amendment covered under §127.450(a)(5), the permit shield provisions in 25 Pa. Code § 127.516 (relating to permit shield) shall apply to administrative permit amendments incorporated in this Title V Permit in accordance with §127.450(c), unless precluded by the Clean Air Act or the regulations thereunder.

**#017 [25 Pa. Code § 127.512(b)]****Severability Clause**

The provisions of this permit are severable, and if any provision of this permit is determined by the Environmental Hearing Board or a court of competent jurisdiction, or US EPA to be invalid or unenforceable, such a determination will not affect the remaining provisions of this permit.

**#018 [25 Pa. Code §§ 127.704, 127.705 & 127.707]****Fee Payment**

(a) The permittee shall pay fees to the Department in accordance with the applicable fee schedules in 25 Pa. Code Chapter 127, Subchapter I (relating to plan approval and operating permit fees). The applicable fees shall be made payable to "The Commonwealth of Pennsylvania Clean Air Fund" with the permit number clearly indicated and submitted to the respective regional office.

(b) Emission Fees. The permittee shall, on or before September 1st of each year, pay applicable annual Title V emission fees for emissions occurring in the previous calendar year as specified in 25 Pa. Code § 127.705. The permittee is not required to pay an emission fee for emissions of more than 4,000 tons of each regulated pollutant emitted from the facility.

(c) As used in this permit condition, the term "regulated pollutant" is defined as a VOC, each pollutant regulated under Sections 111 and 112 of the Clean Air Act and each pollutant for which a National Ambient Air Quality Standard has been promulgated, except that carbon monoxide is excluded.

**SECTION B. General Title V Requirements**

(d) Late Payment. Late payment of emission fees will subject the permittee to the penalties prescribed in 25 Pa. Code § 127.707 and may result in the suspension or termination of the Title V permit. The permittee shall pay a penalty of fifty percent (50%) of the fee amount, plus interest on the fee amount computed in accordance with 26 U.S.C.A. § 6621(a)(2) from the date the emission fee should have been paid in accordance with the time frame specified in 25 Pa. Code § 127.705(c).

(e) The permittee shall pay an annual operating permit maintenance fee according to the following fee schedule established in 25 Pa. Code § 127.704(d) on or before December 31 of each year for the next calendar year.

(1) Eight thousand dollars (\$8,000) for calendar years 2021—2025.

(2) Ten thousand dollars (\$10,000) for calendar years 2026—2030.

(3) Twelve thousand five hundred dollars (\$12,500) for the calendar years beginning with 2031.

**#019 [25 Pa. Code §§ 127.14(b) & 127.449]****Authorization for De Minimis Emission Increases**

(a) This permit authorizes de minimis emission increases from a new or existing source in accordance with 25 Pa. Code §§ 127.14 and 127.449 without the need for a plan approval or prior issuance of a permit modification. The permittee shall provide the Department with seven (7) days prior written notice before commencing any de minimis emissions increase that would result from either: (1) a physical change of minor significance under § 127.14(c)(1); or (2) the construction, installation, modification or reactivation of an air contamination source. The written notice shall:

(1) Identify and describe the pollutants that will be emitted as a result of the de minimis emissions increase.

(2) Provide emission rates expressed in tons per year and in terms necessary to establish compliance consistent with any applicable requirement.

The Department may disapprove or condition de minimis emission increases at any time.

(b) Except as provided below in (c) and (d) of this permit condition, the permittee is authorized during the term of this permit to make de minimis emission increases (expressed in tons per year) up to the following amounts without the need for a plan approval or prior issuance of a permit modification:

(1) Four tons of carbon monoxide from a single source during the term of the permit and 20 tons of carbon monoxide at the facility during the term of the permit.

(2) One ton of NO<sub>x</sub> from a single source during the term of the permit and 5 tons of NO<sub>x</sub> at the facility during the term of the permit.

(3) One and six-tenths tons of the oxides of sulfur from a single source during the term of the permit and 8.0 tons of oxides of sulfur at the facility during the term of the permit.

(4) Six-tenths of a ton of PM<sub>10</sub> from a single source during the term of the permit and 3.0 tons of PM<sub>10</sub> at the facility during the term of the permit. This shall include emissions of a pollutant regulated under Section 112 of the Clean Air Act unless precluded by the Clean Air Act or 25 Pa. Code Article III.

(5) One ton of VOCs from a single source during the term of the permit and 5.0 tons of VOCs at the facility during the term of the permit. This shall include emissions of a pollutant regulated under Section 112 of the Clean Air Act unless precluded by the Clean Air Act or 25 Pa. Code Article III.

(c) In accordance with § 127.14, the permittee may install the following minor sources without the need for a plan approval:

(1) Air conditioning or ventilation systems not designed to remove pollutants generated or released from other sources.

(2) Combustion units rated at 2,500,000 or less Btu per hour of heat input.

**SECTION B. General Title V Requirements**

(3) Combustion units with a rated capacity of less than 10,000,000 Btu per hour heat input fueled by natural gas supplied by a public utility, liquefied petroleum gas or by commercial fuel oils which are No. 2 or lighter, viscosity less than or equal to 5.82 c St, and which meet the sulfur content requirements of 25 Pa. Code § 123.22 (relating to combustion units). For purposes of this permit, commercial fuel oil shall be virgin oil which has no reprocessed, recycled or waste material added.

(4) Space heaters which heat by direct heat transfer.

(5) Laboratory equipment used exclusively for chemical or physical analysis.

(6) Other sources and classes of sources determined to be of minor significance by the Department.

(d) This permit does not authorize de minimis emission increases if the emissions increase would cause one or more of the following:

(1) Increase the emissions of a pollutant regulated under Section 112 of the Clean Air Act except as authorized in Subparagraphs (b)(4) and (5) of this permit condition.

(2) Subject the facility to the prevention of significant deterioration requirements in 25 Pa. Code Chapter 127, Subchapter D and/or the new source review requirements in Subchapter E.

(3) Violate any applicable requirement of the Air Pollution Control Act, the Clean Air Act, or the regulations promulgated under either of the acts.

(4) Changes which are modifications under any provision of Title I of the Clean Air Act and emission increases which would exceed the allowable emissions level (expressed as a rate of emissions or in terms of total emissions) under the Title V permit.

(e) Unless precluded by the Clean Air Act or the regulations thereunder, the permit shield described in 25 Pa. Code § 127.516 (relating to permit shield) shall extend to the changes made under 25 Pa. Code § 127.449 (relating to de minimis emission increases).

(f) Emissions authorized under this permit condition shall be included in the monitoring, recordkeeping and reporting requirements of this permit.

(g) Except for de minimis emission increases allowed under this permit, 25 Pa. Code § 127.449, or sources and physical changes meeting the requirements of 25 Pa. Code § 127.14, the permittee is prohibited from making physical changes or engaging in activities that are not specifically authorized under this permit without first applying for a plan approval. In accordance with § 127.14(b), a plan approval is not required for the construction, modification, reactivation, or installation of the sources creating the de minimis emissions increase.

(h) The permittee may not meet de minimis emission threshold levels by offsetting emission increases or decreases at the same source.

**#020 [25 Pa. Code §§ 127.11a & 127.215]****Reactivation of Sources**

(a) The permittee may reactivate a source at the facility that has been out of operation or production for at least one year, but less than or equal to five (5) years, if the source is reactivated in accordance with the requirements of 25 Pa. Code §§ 127.11a and 127.215. The reactivated source will not be considered a new source.

(b) A source which has been out of operation or production for more than five (5) years but less than 10 years may be reactivated and will not be considered a new source if the permittee satisfies the conditions specified in 25 Pa. Code § 127.11a(b).

**#021 [25 Pa. Code §§ 121.9 & 127.216]****Circumvention**

(a) The owner of this Title V facility, or any other person, may not circumvent the new source review requirements of 25 Pa. Code Chapter 127, Subchapter E by causing or allowing a pattern of ownership or development, including the

**SECTION B. General Title V Requirements**

phasing, staging, delaying or engaging in incremental construction, over a geographic area of a facility which, except for the pattern of ownership or development, would otherwise require a permit or submission of a plan approval application.

(b) No person may permit the use of a device, stack height which exceeds good engineering practice stack height, dispersion technique or other technique which, without resulting in reduction of the total amount of air contaminants emitted, conceals or dilutes an emission of air contaminants which would otherwise be in violation of this permit, the Air Pollution Control Act or the regulations promulgated thereunder, except that with prior approval of the Department, the device or technique may be used for control of malodors.

**#022 [25 Pa. Code §§ 127.402(d) & 127.513(1)]****Submissions**

(a) Reports, test data, monitoring data, notifications and requests for renewal of the permit shall be submitted to the:

Regional Air Program Manager  
PA Department of Environmental Protection  
(At the address given on the permit transmittal letter, or otherwise notified)

(b) Any report or notification for the EPA Administrator or EPA Region III should be addressed to:

Enforcement & Compliance Assurance Division  
Air, RCRA and Toxics Branch (3ED21)  
Four Penn Center  
1600 John F. Kennedy Boulevard  
Philadelphia, PA 19103-2852

The Title V compliance certification shall be emailed to EPA at R3\_APD\_Permits@epa.gov.

(c) An application, form, report or compliance certification submitted pursuant to this permit condition shall contain certification by a responsible official as to truth, accuracy, and completeness as required under 25 Pa. Code § 127.402(d). Unless otherwise required by the Clean Air Act or regulations adopted thereunder, this certification and any other certification required pursuant to this permit shall state that, based on information and belief formed after reasonable inquiry, the statements and information in the document are true, accurate and complete.

**#023 [25 Pa. Code §§ 127.441(c) & 127.463(e); Chapter 139; & 114(a)(3), 504(b) of the CAA]****Sampling, Testing and Monitoring Procedures**

(a) The permittee shall perform the emissions monitoring and analysis procedures or test methods for applicable requirements of this Title V permit. In addition to the sampling, testing and monitoring procedures specified in this permit, the Permittee shall comply with any additional applicable requirements promulgated under the Clean Air Act after permit issuance regardless of whether the permit is revised.

(b) The sampling, testing and monitoring required under the applicable requirements of this permit, shall be conducted in accordance with the requirements of 25 Pa. Code Chapter 139 unless alternative methodology is required by the Clean Air Act (including §§ 114(a)(3) and 504(b)) and regulations adopted thereunder.

**#024 [25 Pa. Code §§ 127.511 & Chapter 135]****Recordkeeping Requirements**

(a) The permittee shall maintain and make available, upon request by the Department, records of required monitoring information that include the following:

- (1) The date, place (as defined in the permit) and time of sampling or measurements.
- (2) The dates the analyses were performed.
- (3) The company or entity that performed the analyses.
- (4) The analytical techniques or methods used.

**SECTION B. General Title V Requirements**

(5) The results of the analyses.

(6) The operating conditions as existing at the time of sampling or measurement.

(b) The permittee shall retain records of the required monitoring data and supporting information for at least five (5) years from the date of the monitoring sample, measurement, report or application. Supporting information includes the calibration data and maintenance records and original strip-chart recordings for continuous monitoring instrumentation, and copies of reports required by the permit.

(c) The permittee shall maintain and make available to the Department upon request, records including computerized records that may be necessary to comply with the reporting, recordkeeping and emission statement requirements in 25 Pa. Code Chapter 135 (relating to reporting of sources). In accordance with 25 Pa. Code Chapter 135, § 135.5, such records may include records of production, fuel usage, maintenance of production or pollution control equipment or other information determined by the Department to be necessary for identification and quantification of potential and actual air contaminant emissions. If direct recordkeeping is not possible or practical, sufficient records shall be kept to provide the needed information by indirect means.

**#025 [25 Pa. Code §§ 127.411(d), 127.442, 127.463(e) & 127.511(c)]****Reporting Requirements**

(a) The permittee shall comply with the reporting requirements for the applicable requirements specified in this Title V permit. In addition to the reporting requirements specified herein, the permittee shall comply with any additional applicable reporting requirements promulgated under the Clean Air Act after permit issuance regardless of whether the permit is revised.

(b) Pursuant to 25 Pa. Code § 127.511(c), the permittee shall submit reports of required monitoring at least every six (6) months unless otherwise specified in this permit. Instances of deviations (as defined in 25 Pa. Code § 121.1) from permit requirements shall be clearly identified in the reports. The reporting of deviations shall include the probable cause of the deviations and corrective actions or preventative measures taken, except that sources with continuous emission monitoring systems shall report according to the protocol established and approved by the Department for the source. The required reports shall be certified by a responsible official.

(c) Every report submitted to the Department under this permit condition shall comply with the submission procedures specified in Section B, Condition #022(c) of this permit.

(d) Any records, reports or information obtained by the Department or referred to in a public hearing shall be made available to the public by the Department except for such records, reports or information for which the permittee has shown cause that the documents should be considered confidential and protected from disclosure to the public under Section 4013.2 of the Air Pollution Control Act and consistent with Sections 112(d) and 114(c) of the Clean Air Act and 25 Pa. Code § 127.411(d). The permittee may not request a claim of confidentiality for any emissions data generated for the Title V facility.

**#026 [25 Pa. Code § 127.513]****Compliance Certification**

(a) One year after the date of issuance of the Title V permit, and each year thereafter, unless specified elsewhere in the permit, the permittee shall submit to the Department and EPA Region III a certificate of compliance with the terms and conditions in this permit, for the previous year, including the emission limitations, standards or work practices. This certification shall include:

- (1) The identification of each term or condition of the permit that is the basis of the certification.
- (2) The compliance status.
- (3) The methods used for determining the compliance status of the source, currently and over the reporting period.
- (4) Whether compliance was continuous or intermittent.

(b) The compliance certification shall be postmarked or hand-delivered no later than thirty days after each anniversary of the date of issuance of this Title V Operating Permit, or on the submittal date specified elsewhere in the permit, to the Department in accordance with the submission requirements specified in Section B, Condition #022 of this permit. The Title V compliance certification shall be emailed to EPA at R3\_APD\_Permits@epa.gov.

**SECTION B. General Title V Requirements****#027 [25 Pa. Code § 127.3]****Operational Flexibility**

The permittee is authorized to make changes within the Title V facility in accordance with the following provisions in 25 Pa. Code Chapter 127 which implement the operational flexibility requirements of Section 502(b)(10) of the Clean Air Act and Section 6.1(i) of the Air Pollution Control Act:

- (1) Section 127.14 (relating to exemptions)
- (2) Section 127.447 (relating to alternative operating scenarios)
- (3) Section 127.448 (relating to emissions trading at facilities with federally enforceable emissions caps)
- (4) Section 127.449 (relating to de minimis emission increases)
- (5) Section 127.450 (relating to administrative operating permit amendments)
- (6) Section 127.462 (relating to minor operating permit amendments)
- (7) Subchapter H (relating to general plan approvals and operating permits)

**#028 [25 Pa. Code §§ 127.441(d), 127.512(i) and 40 CFR Part 68]****Risk Management**

(a) If required by Section 112(r) of the Clean Air Act, the permittee shall develop and implement an accidental release program consistent with requirements of the Clean Air Act, 40 CFR Part 68 (relating to chemical accident prevention provisions) and the Federal Chemical Safety Information, Site Security and Fuels Regulatory Relief Act (P.L. 106-40).

(b) The permittee shall prepare and implement a Risk Management Plan (RMP) which meets the requirements of Section 112(r) of the Clean Air Act, 40 CFR Part 68 and the Federal Chemical Safety Information, Site Security and Fuels Regulatory Relief Act when a regulated substance listed in 40 CFR § 68.130 is present in a process in more than the listed threshold quantity at the Title V facility. The permittee shall submit the RMP to the federal Environmental Protection Agency according to the following schedule and requirements:

- (1) The permittee shall submit the first RMP to a central point specified by EPA no later than the latest of the following:
  - (i) Three years after the date on which a regulated substance is first listed under § 68.130; or,
  - (ii) The date on which a regulated substance is first present above a threshold quantity in a process.

(2) The permittee shall submit any additional relevant information requested by the Department or EPA concerning the RMP and shall make subsequent submissions of RMPs in accordance with 40 CFR § 68.190.

(3) The permittee shall certify that the RMP is accurate and complete in accordance with the requirements of 40 CFR Part 68, including a checklist addressing the required elements of a complete RMP.

(c) As used in this permit condition, the term "process" shall be as defined in 40 CFR § 68.3. The term "process" means any activity involving a regulated substance including any use, storage, manufacturing, handling, or on-site movement of such substances or any combination of these activities. For purposes of this definition, any group of vessels that are interconnected, or separate vessels that are located such that a regulated substance could be involved in a potential release, shall be considered a single process.

(d) If the Title V facility is subject to 40 CFR Part 68, as part of the certification required under this permit, the permittee shall:

- (1) Submit a compliance schedule for satisfying the requirements of 40 CFR Part 68 by the date specified in 40 CFR § 68.10(a); or,
- (2) Certify that the Title V facility is in compliance with all requirements of 40 CFR Part 68 including the registration and submission of the RMP.



**SECTION B. General Title V Requirements**

(e) If the Title V facility is subject to 40 CFR Part 68, the permittee shall maintain records supporting the implementation of an accidental release program for five (5) years in accordance with 40 CFR § 68.200.

(f) When the Title V facility is subject to the accidental release program requirements of Section 112(r) of the Clean Air Act and 40 CFR Part 68, appropriate enforcement action will be taken by the Department if:

(1) The permittee fails to register and submit the RMP or a revised plan pursuant to 40 CFR Part 68.

(2) The permittee fails to submit a compliance schedule or include a statement in the compliance certification required under Section B, Condition #026 of this permit that the Title V facility is in compliance with the requirements of Section 112(r) of the Clean Air Act, 40 CFR Part 68, and 25 Pa. Code § 127.512(i).

**#029 [25 Pa. Code § 127.512(e)]****Approved Economic Incentives and Emission Trading Programs**

No permit revision shall be required under approved economic incentives, marketable permits, emissions trading and other similar programs or processes for changes that are provided for in this Title V permit.

**#030 [25 Pa. Code §§ 127.516, 127.450(d), 127.449(f) & 127.462(g)]****Permit Shield**

(a) The permittee's compliance with the conditions of this permit shall be deemed in compliance with applicable requirements (as defined in 25 Pa. Code § 121.1) as of the date of permit issuance if either of the following applies:

(1) The applicable requirements are included and are specifically identified in this permit.

(2) The Department specifically identifies in the permit other requirements that are not applicable to the permitted facility or source.

(b) Nothing in 25 Pa. Code § 127.516 or the Title V permit shall alter or affect the following:

(1) The provisions of Section 303 of the Clean Air Act, including the authority of the Administrator of the EPA provided thereunder.

(2) The liability of the permittee for a violation of an applicable requirement prior to the time of permit issuance.

(3) The applicable requirements of the acid rain program, consistent with Section 408(a) of the Clean Air Act.

(4) The ability of the EPA to obtain information from the permittee under Section 114 of the Clean Air Act.

(c) Unless precluded by the Clean Air Act or regulations thereunder, final action by the Department incorporating a significant permit modification in this Title V Permit shall be covered by the permit shield at the time that the permit containing the significant modification is issued.

**#031 [25 Pa. Code §135.3]****Reporting**

(a) The permittee shall submit by March 1 of each year an annual emissions report for the preceding calendar year. The report shall include information for all active previously reported sources, new sources which were first operated during the preceding calendar year, and sources modified during the same period which were not previously reported. All air emissions from the facility should be estimated and reported.

(b) A source owner or operator may request an extension of time from the Department for the filing of an annual emissions report, and the Department may grant the extension for reasonable cause.

**#032 [25 Pa. Code §135.4]****Report Format**

Emissions reports shall contain sufficient information to enable the Department to complete its emission inventory. Emissions reports shall be made by the source owner or operator in a format specified by the Department.



**SECTION C. Site Level Requirements****I. RESTRICTIONS.****Emission Restriction(s).****# 001 [25 Pa. Code §123.1]****Prohibition of certain fugitive emissions**

No person may emit any fugitive air contaminant into the outdoor atmosphere from the sources other than the following:

- (1) Construction or demolition of buildings or structures.
- (2) Grading, paving and maintenance of roads and streets.
- (3) Use of roads and streets. Emissions from material in or on trucks, railroad cars and other vehicular equipment are not considered as emissions from use of roads and streets.
- (4) Clearing of land.
- (5) Stockpiling of materials.
- (6) Open burning operations.
- (7) Sources and classes of sources other than those identified in paragraphs (1) - (6), above for which the operator has obtained a determination from the Department in accordance with 25 Pa Code Section 123.1 (b) that fugitive emissions from the source, after appropriate control, meet the following requirements:
  - (i) The emissions are of minor significance with respect to causing air pollution; and
  - (ii) The emissions are not preventing or interfering with the attainment or maintenance of any ambient air standard.

**# 002 [25 Pa. Code §123.2]****Fugitive particulate matter**

No person may permit fugitive particulate matter emissions into the outdoor atmosphere from a source specified in the preceding permit condition #001, if such emissions are visible at the point the emissions pass outside the person's property.

**# 003 [25 Pa. Code §123.31]****Limitations**

No person may emit any malodorous air contaminants into the outdoor atmosphere from any source in such a manner that the malodors are detectable outside the property of the permittee on whose land the source is being operated.

**# 004 [25 Pa. Code §129.14]****Open burning operations**

- (a) No person shall permit the open burning of material in such a manner that:
  - (1) The emissions are visible, at any time, at the point such emissions pass outside the property of the person on whose land the open burning is being conducted.
  - (2) Malodorous air contaminants from the open burning are detectable outside the property of the person on whose land the open burning is being conducted.
  - (3) The emissions interfere with the reasonable enjoyment of life or property.
  - (4) The emissions cause damage to vegetation or property.
  - (5) The emissions are or may be deleterious to human health.

**SECTION C. Site Level Requirements**

- (b) Exceptions: The requirements of subsections (a) above do not apply where the open burning operations result from:
- (1) A fire set to prevent or abate a fire hazard, when approved by the Department and set by or under the supervision of a public officer.
  - (2) A fire set for the purpose of instructing personnel in fire fighting, when approved by the Department.
  - (3) A fire set for the prevention and control of disease or pests, when approved by the Department.
  - (4) A fire set solely for recreational or ceremonial purposes.
  - (5) A fire set solely for cooking food.

**II. TESTING REQUIREMENTS.**

No additional testing requirements exist except as provided in other sections of this permit including Section B (Title V General Requirements).

**III. MONITORING REQUIREMENTS.**

**# 005 [25 Pa. Code §127.441]  
Operating permit terms and conditions.**

The permittee shall conduct a daily inspection around the plant periphery during daylight hours when the plant is in production to detect fugitive visible emissions, and malodorous emissions as follows:

- (a) The presence of fugitive emissions visible beyond the plant boundaries as stated in Section C, condition # 002.
- (b) The presence of malodorous air emissions beyond the plant boundaries as stated in Section C, condition #003.

**IV. RECORDKEEPING REQUIREMENTS.**

**# 006 [25 Pa. Code §127.511]  
Monitoring and related recordkeeping and reporting requirements.**

- (a) The permittee shall maintain a logbook for recording the status of malodorous air contaminants and visible fugitive emission exceedences.
- (b) The logbook shall include the name of the company representative, the date and time the monitoring was conducted, wind direction and actions taken to correct the problem. A log entry is required for each inspection irrespective of whether or not any odorous or fugitive emissions were detected.

**V. REPORTING REQUIREMENTS.**

**# 007 [25 Pa. Code §127.512]  
Operating permit terms and conditions.**

(a) The permittee shall report malfunctions which occur at the facility to the Department as defined in 40 CFR Subpart 60.2, a malfunction is any sudden, infrequent, and not reasonably preventable failure of air pollution control and monitoring equipment, process equipment, or a process to operate in a normal or usual manner which causes, or has the potential to cause, the emission limitations in an applicable standard to be exceeded. Failures that are caused in part by poor maintenance or careless operation are not malfunctions.

- (1) Malfunctions which occur at the facility which pose an imminent danger to public health, safety, welfare and the environment, shall be immediately reported to the Department by the telephone. The telephone report of such malfunctions shall occur no later than two (2) hours after the permittee is aware of the malfunction. The permittee shall submit a written report of instance of such malfunctions to the Department within three (3) days of the telephone report.

**SECTION C. Site Level Requirements**

(2) Unless otherwise required by this permit, any other malfunction that is not subject to the reporting requirements of paragraph (1) above, shall be reported to the DEP, in writing, within five (5) days of discovery of the malfunction.

(b) Unless otherwise approved by DEP, all malfunctions shall be reported through the Department's Greenport PUP system available through:

<https://greenport.pa.gov/ePermitPublicAccess/PublicSubmission/Home>

(c) Telephone reports can be made to the Reading District Office at 610-916-0100 during normal business hours, or to the Department's Emergency Hotline at any time. The Emergency Hotline phone number is changed/updated periodically. The current Emergency Hotline phone number can be found at:

<https://www.dep.pa.gov/About/Regional/SouthcentralRegion/Pages/default.aspx>.

**VI. WORK PRACTICE REQUIREMENTS.****# 008 [25 Pa. Code §123.1]****Prohibition of certain fugitive emissions**

A person responsible for any source specified in Section C, Condition #001 above, shall take all reasonable actions to prevent particulate matter from becoming airborne. These actions shall include, but not be limited to, the following:

(1) Use, where possible, of water or chemicals for control of dust in the demolition of buildings or structures, construction operations, the grading of roads, or the clearing of land.

(2) Application of asphalt, oil, water or suitable chemicals on dirt roads, material stockpiles and other surfaces which may give rise to airborne dusts.

(3) Paving and maintenance of roadways.

(4) Prompt removal of earth or other material from paved streets onto which earth or other material has been transported by trucking or earth moving equipment, erosion by water, or other means.

**VII. ADDITIONAL REQUIREMENTS.**

No additional requirements exist except as provided in other sections of this permit including Section B (Title V General Requirements).

**VIII. COMPLIANCE CERTIFICATION.**

The permittee shall submit within thirty days of 01/01/2025 a certificate of compliance with all permit terms and conditions set forth in this Title V permit as required under condition #026 of section B of this permit, and annually thereafter.

**IX. COMPLIANCE SCHEDULE.**

No compliance milestones exist.

**\*\*\* Permit Shield In Effect \*\*\***



**SECTION D. Source Level Requirements**

Source ID: 001

Source Name: MW COMBUSTOR 1

Source Capacity/Throughput: 33,333.000 Lbs/HR  
25,740.000 CF/HR

MUNIC./RESIDUAL/SEWAGE SLU  
PROPANE

Conditions for this source occur in the following groups: G01  
G04  
G05  
G06

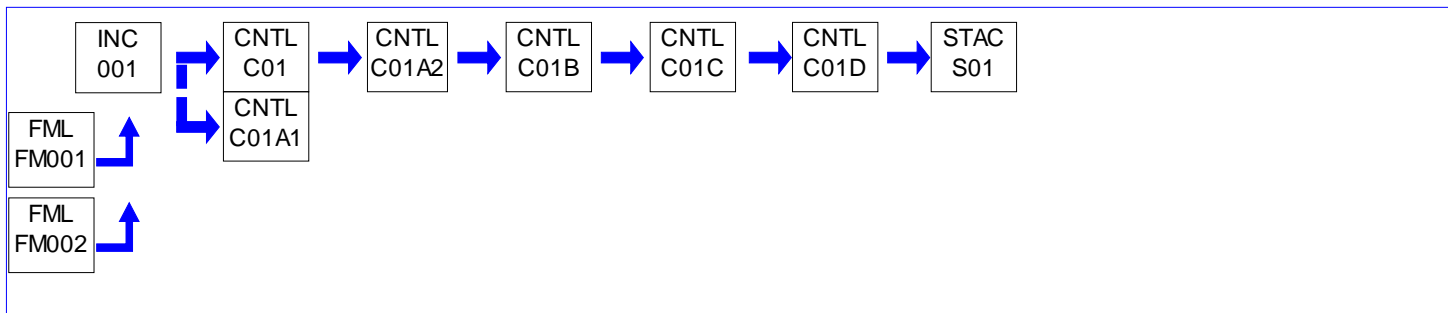

**I. RESTRICTIONS.**

No additional requirements exist except as provided in other sections of this permit including Section B (Title V General Requirements) and/or Section E (Source Group Restrictions).

**II. TESTING REQUIREMENTS.**

No additional testing requirements exist except as provided in other sections of this permit including Section B (Title V General Requirements) and/or Section E (Source Group Restrictions).

**III. MONITORING REQUIREMENTS.**

No additional monitoring requirements exist except as provided in other sections of this permit including Section B (Title V General Requirements) and/or Section E (Source Group Restrictions).

**IV. RECORDKEEPING REQUIREMENTS.**

No additional record keeping requirements exist except as provided in other sections of this permit including Section B (Title V General Requirements) and/or Section E (Source Group Restrictions).

**V. REPORTING REQUIREMENTS.**

No additional reporting requirements exist except as provided in other sections of this permit including Section B (Title V General Requirements) and/or Section E (Source Group Restrictions).

**VI. WORK PRACTICE REQUIREMENTS.**

No additional work practice requirements exist except as provided in other sections of this permit including Section B (Title V General Requirements) and/or Section E (Source Group Restrictions).

**VII. ADDITIONAL REQUIREMENTS.**

No additional requirements exist except as provided in other sections of this permit including Section B (Title V General Requirements) and/or Section E (Source Group Restrictions).



**SECTION D. Source Level Requirements**

**\*\*\* Permit Shield in Effect. \*\*\***



**SECTION D. Source Level Requirements**

Source ID: 002

Source Name: MW COMBUSTOR 2

Source Capacity/Throughput: 33,333.000 Lbs/HR  
25,740.000 CF/HR

MUNIC./RESIDUAL/SEWAGE SLU  
PROPANE

Conditions for this source occur in the following groups: G01  
G04  
G05  
G06

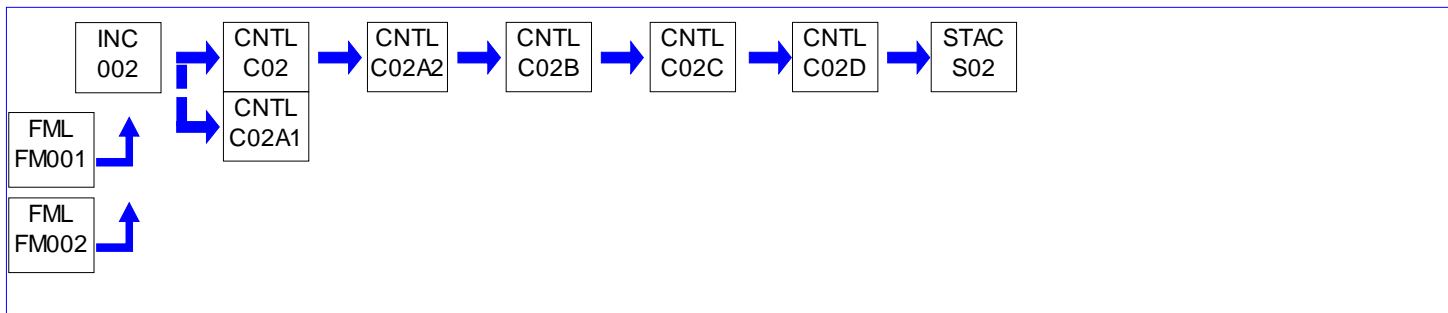

**I. RESTRICTIONS.**

No additional requirements exist except as provided in other sections of this permit including Section B (Title V General Requirements) and/or Section E (Source Group Restrictions).

**II. TESTING REQUIREMENTS.**

No additional testing requirements exist except as provided in other sections of this permit including Section B (Title V General Requirements) and/or Section E (Source Group Restrictions).

**III. MONITORING REQUIREMENTS.**

No additional monitoring requirements exist except as provided in other sections of this permit including Section B (Title V General Requirements) and/or Section E (Source Group Restrictions).

**IV. RECORDKEEPING REQUIREMENTS.**

No additional record keeping requirements exist except as provided in other sections of this permit including Section B (Title V General Requirements) and/or Section E (Source Group Restrictions).

**V. REPORTING REQUIREMENTS.**

No additional reporting requirements exist except as provided in other sections of this permit including Section B (Title V General Requirements) and/or Section E (Source Group Restrictions).

**VI. WORK PRACTICE REQUIREMENTS.**

No additional work practice requirements exist except as provided in other sections of this permit including Section B (Title V General Requirements) and/or Section E (Source Group Restrictions).

**VII. ADDITIONAL REQUIREMENTS.**

No additional requirements exist except as provided in other sections of this permit including Section B (Title V General Requirements) and/or Section E (Source Group Restrictions).



**SECTION D. Source Level Requirements**

**\*\*\* Permit Shield in Effect. \*\*\***



**SECTION D. Source Level Requirements**

Source ID: 003

Source Name: MW COMBUSTOR 3

Source Capacity/Throughput: 33,333.000 Lbs/HR  
25,740.000 CF/HR

MUNIC./RESIDUAL/SEWAGE SLU  
PROPANE

Conditions for this source occur in the following groups: G01  
G04  
G05  
G06

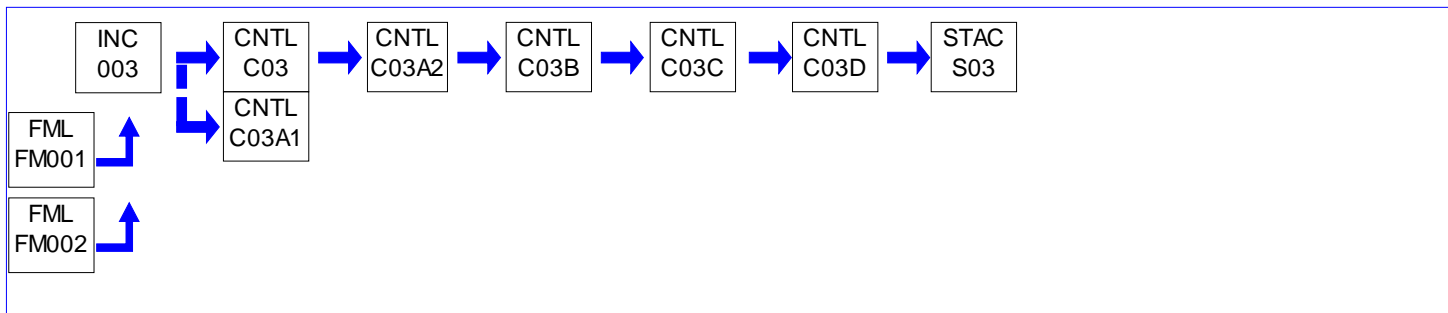

**I. RESTRICTIONS.**

No additional requirements exist except as provided in other sections of this permit including Section B (Title V General Requirements) and/or Section E (Source Group Restrictions).

**II. TESTING REQUIREMENTS.**

No additional testing requirements exist except as provided in other sections of this permit including Section B (Title V General Requirements) and/or Section E (Source Group Restrictions).

**III. MONITORING REQUIREMENTS.**

No additional monitoring requirements exist except as provided in other sections of this permit including Section B (Title V General Requirements) and/or Section E (Source Group Restrictions).

**IV. RECORDKEEPING REQUIREMENTS.**

No additional record keeping requirements exist except as provided in other sections of this permit including Section B (Title V General Requirements) and/or Section E (Source Group Restrictions).

**V. REPORTING REQUIREMENTS.**

No additional reporting requirements exist except as provided in other sections of this permit including Section B (Title V General Requirements) and/or Section E (Source Group Restrictions).

**VI. WORK PRACTICE REQUIREMENTS.**

No additional work practice requirements exist except as provided in other sections of this permit including Section B (Title V General Requirements) and/or Section E (Source Group Restrictions).

**VII. ADDITIONAL REQUIREMENTS.**

No additional requirements exist except as provided in other sections of this permit including Section B (Title V General Requirements) and/or Section E (Source Group Restrictions).





**SECTION D. Source Level Requirements**

**\*\*\* Permit Shield in Effect. \*\*\***

**SECTION D. Source Level Requirements**

Source ID: 004

Source Name: HYDRATED LIME SILO

Source Capacity/Throughput:

Conditions for this source occur in the following groups: G02

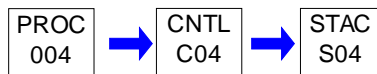
**I. RESTRICTIONS.**

No additional requirements exist except as provided in other sections of this permit including Section B (Title V General Requirements) and/or Section E (Source Group Restrictions).

**II. TESTING REQUIREMENTS.**

No additional testing requirements exist except as provided in other sections of this permit including Section B (Title V General Requirements) and/or Section E (Source Group Restrictions).

**III. MONITORING REQUIREMENTS.**

No additional monitoring requirements exist except as provided in other sections of this permit including Section B (Title V General Requirements) and/or Section E (Source Group Restrictions).

**IV. RECORDKEEPING REQUIREMENTS.**

No additional record keeping requirements exist except as provided in other sections of this permit including Section B (Title V General Requirements) and/or Section E (Source Group Restrictions).

**V. REPORTING REQUIREMENTS.**

No additional reporting requirements exist except as provided in other sections of this permit including Section B (Title V General Requirements) and/or Section E (Source Group Restrictions).

**VI. WORK PRACTICE REQUIREMENTS.**

No additional work practice requirements exist except as provided in other sections of this permit including Section B (Title V General Requirements) and/or Section E (Source Group Restrictions).

**VII. ADDITIONAL REQUIREMENTS.**

No additional requirements exist except as provided in other sections of this permit including Section B (Title V General Requirements) and/or Section E (Source Group Restrictions).

**\*\*\* Permit Shield in Effect. \*\*\***

**SECTION D. Source Level Requirements**

Source ID: 005

Source Name: PEBBLE LIME SILO

Source Capacity/Throughput:

Conditions for this source occur in the following groups: G02

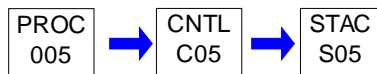
**I. RESTRICTIONS.**

No additional requirements exist except as provided in other sections of this permit including Section B (Title V General Requirements) and/or Section E (Source Group Restrictions).

**II. TESTING REQUIREMENTS.**

No additional testing requirements exist except as provided in other sections of this permit including Section B (Title V General Requirements) and/or Section E (Source Group Restrictions).

**III. MONITORING REQUIREMENTS.**

No additional monitoring requirements exist except as provided in other sections of this permit including Section B (Title V General Requirements) and/or Section E (Source Group Restrictions).

**IV. RECORDKEEPING REQUIREMENTS.**

No additional record keeping requirements exist except as provided in other sections of this permit including Section B (Title V General Requirements) and/or Section E (Source Group Restrictions).

**V. REPORTING REQUIREMENTS.**

No additional reporting requirements exist except as provided in other sections of this permit including Section B (Title V General Requirements) and/or Section E (Source Group Restrictions).

**VI. WORK PRACTICE REQUIREMENTS.**

No additional work practice requirements exist except as provided in other sections of this permit including Section B (Title V General Requirements) and/or Section E (Source Group Restrictions).

**VII. ADDITIONAL REQUIREMENTS.**

No additional requirements exist except as provided in other sections of this permit including Section B (Title V General Requirements) and/or Section E (Source Group Restrictions).

**\*\*\* Permit Shield in Effect. \*\*\***

**SECTION D. Source Level Requirements**

Source ID: 006

Source Name: FIRE PUMP DIESEL ENGINE

Source Capacity/Throughput:

5.000 Gal/HR

DIESEL FUEL

Conditions for this source occur in the following groups: G03

**I. RESTRICTIONS.****Emission Restriction(s).****# 001 [25 Pa. Code §123.21]****General**

No person shall permit the emission from the above engine into the outdoor atmosphere in a manner that the concentration of sulfur oxides (SO<sub>x</sub>), expressed as SO<sub>2</sub>, in the effluent gas is in excess of 500 ppm, by volume, dry basis.

**# 002 [25 Pa. Code §129.13]****Sulfur recovery plants**

No person may permit the emission into the outdoor atmosphere of particulate matter from the above engine, at any time, in a manner that the concentration of particulate matter in the effluent gas exceeds 0.04 grains per dry standard cubic foot.

**# 003 [25 Pa. Code §129.93]****Presumptive RACT emission limitations**

The permittee shall limit the operation of the above engine to less than 500 hours in any consecutive 12-month rolling period.

**II. TESTING REQUIREMENTS.**

No additional testing requirements exist except as provided in other sections of this permit including Section B (Title V General Requirements) and/or Section E (Source Group Restrictions).

**III. MONITORING REQUIREMENTS.**

No additional monitoring requirements exist except as provided in other sections of this permit including Section B (Title V General Requirements) and/or Section E (Source Group Restrictions).

**IV. RECORDKEEPING REQUIREMENTS.****# 004 [25 Pa. Code §129.93]****Presumptive RACT emission limitations**

(a) The permittee shall keep a record of the total operating hours for the above engine. The operating hours shall be summed on a monthly basis, and added to the previous 11-month total in determining the 12-month rolling total as defined in Condition #003, above.

(b) The records shall be maintained at the facility for a period of five (5) years and be made available to the Department upon request.



## SECTION D. Source Level Requirements

### V. REPORTING REQUIREMENTS.

No additional reporting requirements exist except as provided in other sections of this permit including Section B (Title V General Requirements) and/or Section E (Source Group Restrictions).

### VI. WORK PRACTICE REQUIREMENTS.

No additional work practice requirements exist except as provided in other sections of this permit including Section B (Title V General Requirements) and/or Section E (Source Group Restrictions).

### VII. ADDITIONAL REQUIREMENTS.

No additional requirements exist except as provided in other sections of this permit including Section B (Title V General Requirements) and/or Section E (Source Group Restrictions).

**\*\*\* Permit Shield in Effect. \*\*\***

**SECTION D. Source Level Requirements**

Source ID: 007

Source Name: PAVED ROAD

Source Capacity/Throughput:

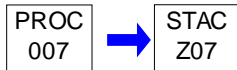
**I. RESTRICTIONS.**

No additional requirements exist except as provided in other sections of this permit including Section B (Title V General Requirements).

**II. TESTING REQUIREMENTS.**

No additional testing requirements exist except as provided in other sections of this permit including Section B (Title V General Requirements).

**III. MONITORING REQUIREMENTS.**

No additional monitoring requirements exist except as provided in other sections of this permit including Section B (Title V General Requirements).

**IV. RECORDKEEPING REQUIREMENTS.**

No additional record keeping requirements exist except as provided in other sections of this permit including Section B (Title V General Requirements).

**V. REPORTING REQUIREMENTS.**

No additional reporting requirements exist except as provided in other sections of this permit including Section B (Title V General Requirements).

**VI. WORK PRACTICE REQUIREMENTS.**

No additional work practice requirements exist except as provided in other sections of this permit including Section B (Title V General Requirements).

**VII. ADDITIONAL REQUIREMENTS.**

No additional requirements exist except as provided in other sections of this permit including Section B (Title V General Requirements).

**\*\*\* Permit Shield in Effect. \*\*\***

**SECTION D. Source Level Requirements**

Source ID: 008

Source Name: ACTIVATED CARBON STORAGE SILO

Source Capacity/Throughput:

Conditions for this source occur in the following groups: G02

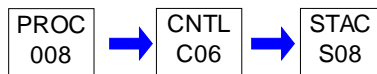
**I. RESTRICTIONS.**

No additional requirements exist except as provided in other sections of this permit including Section B (Title V General Requirements) and/or Section E (Source Group Restrictions).

**II. TESTING REQUIREMENTS.**

No additional testing requirements exist except as provided in other sections of this permit including Section B (Title V General Requirements) and/or Section E (Source Group Restrictions).

**III. MONITORING REQUIREMENTS.**

No additional monitoring requirements exist except as provided in other sections of this permit including Section B (Title V General Requirements) and/or Section E (Source Group Restrictions).

**IV. RECORDKEEPING REQUIREMENTS.**

No additional record keeping requirements exist except as provided in other sections of this permit including Section B (Title V General Requirements) and/or Section E (Source Group Restrictions).

**V. REPORTING REQUIREMENTS.**

No additional reporting requirements exist except as provided in other sections of this permit including Section B (Title V General Requirements) and/or Section E (Source Group Restrictions).

**VI. WORK PRACTICE REQUIREMENTS.**

No additional work practice requirements exist except as provided in other sections of this permit including Section B (Title V General Requirements) and/or Section E (Source Group Restrictions).

**VII. ADDITIONAL REQUIREMENTS.**

No additional requirements exist except as provided in other sections of this permit including Section B (Title V General Requirements) and/or Section E (Source Group Restrictions).

**\*\*\* Permit Shield in Effect. \*\*\***

**SECTION D. Source Level Requirements**

Source ID: 009

Source Name: EMERGENCY GENERATOR

Source Capacity/Throughput:

7.200 Gal/HR

Propane

Conditions for this source occur in the following groups: G03

**I. RESTRICTIONS.****Emission Restriction(s).****# 001 [25 Pa. Code §123.21]****General**

No person shall permit the emission from the above engine into the outdoor atmosphere in a manner that the concentration of sulfur oxides (SO<sub>x</sub>), expressed as SO<sub>2</sub>, in the effluent gas is in excess of 500 ppm, by volume, dry basis.

**# 002 [25 Pa. Code §129.13]****Sulfur recovery plants**

No person may permit the emission into the outdoor atmosphere of particulate matter from the above engine, at any time, in a manner that the concentration of particulate matter in the effluent gas exceeds 0.04 grains per dry standard cubic foot.

**# 003 [25 Pa. Code §129.93]****Presumptive RACT emission limitations**

The permittee shall limit the operation of the above engine to less than 500 hours in any consecutive 12-month rolling period.

**II. TESTING REQUIREMENTS.**

No additional testing requirements exist except as provided in other sections of this permit including Section B (Title V General Requirements) and/or Section E (Source Group Restrictions).

**III. MONITORING REQUIREMENTS.**

No additional monitoring requirements exist except as provided in other sections of this permit including Section B (Title V General Requirements) and/or Section E (Source Group Restrictions).

**IV. RECORDKEEPING REQUIREMENTS.****# 004 [25 Pa. Code §129.93]****Presumptive RACT emission limitations**

(a) The permittee shall keep a record of the total operating hours for the above engine. The operating hours shall be summed on a monthly basis, and added to the previous 11-month total in determining the 12-month rolling total as defined in Condition #003, above.

(b) The records shall be maintained at the facility for a period of five (5) years and be made available to the Department upon request.





## SECTION D. Source Level Requirements

### V. REPORTING REQUIREMENTS.

No additional reporting requirements exist except as provided in other sections of this permit including Section B (Title V General Requirements) and/or Section E (Source Group Restrictions).

### VI. WORK PRACTICE REQUIREMENTS.

No additional work practice requirements exist except as provided in other sections of this permit including Section B (Title V General Requirements) and/or Section E (Source Group Restrictions).

### VII. ADDITIONAL REQUIREMENTS.

No additional requirements exist except as provided in other sections of this permit including Section B (Title V General Requirements) and/or Section E (Source Group Restrictions).

**\*\*\* Permit Shield in Effect. \*\*\***

**SECTION D. Source Level Requirements**

Source ID: 010

Source Name: COOLING TOWER

Source Capacity/Throughput:

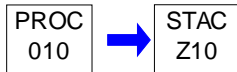
**I. RESTRICTIONS.**

No additional requirements exist except as provided in other sections of this permit including Section B (Title V General Requirements).

**II. TESTING REQUIREMENTS.**

No additional testing requirements exist except as provided in other sections of this permit including Section B (Title V General Requirements).

**III. MONITORING REQUIREMENTS.**

No additional monitoring requirements exist except as provided in other sections of this permit including Section B (Title V General Requirements).

**IV. RECORDKEEPING REQUIREMENTS.**

No additional record keeping requirements exist except as provided in other sections of this permit including Section B (Title V General Requirements).

**V. REPORTING REQUIREMENTS.**

No additional reporting requirements exist except as provided in other sections of this permit including Section B (Title V General Requirements).

**VI. WORK PRACTICE REQUIREMENTS.**

No additional work practice requirements exist except as provided in other sections of this permit including Section B (Title V General Requirements).

**VII. ADDITIONAL REQUIREMENTS.**

No additional requirements exist except as provided in other sections of this permit including Section B (Title V General Requirements).

**\*\*\* Permit Shield in Effect. \*\*\***

**SECTION E. Source Group Restrictions.**

Group Name: G01

Group Description: Best Available Technology (BAT) Requirements

Sources included in this group

ID	Name
001	MW COMBUSTOR 1
002	MW COMBUSTOR 2
003	MW COMBUSTOR 3

**I. RESTRICTIONS.****Emission Restriction(s).****# 001 [25 Pa. Code §127.441]****Operating permit terms and conditions.**

(a) Using the actual stack emission rates for the facility and the exhaust parameters from each stack test specified and the dispersion modeling techniques used in Plan Approval No. 36-340-001 as approved by the Department, the calculated maximum annual ambient concentration shall not exceed the following levels:

Contaminants	Ambient Concentration (ug/dscm)
PCDD and PCDF (expressed as 2,3,7,8 TCDD equivalents)	0.3 x 10 <sup>-7</sup>
Arsenic and Compounds	0.23 x 10 <sup>-3</sup>
Beryllium and Compounds	0.42 x 10 <sup>-3</sup>
Cadmium and Compounds	0.56 x 10 <sup>-3</sup>
Nickel and Compounds	0.33 x 10 <sup>-2</sup>
Hexavalent Chromium and Compounds	0.83 x 10 <sup>-4</sup>
Mercury and Compounds	0.08
Lead and Compounds	0.50

(b) Compliance with the ambient concentration limits above shall be demonstrated each time stack sampling is conducted unless all of the following conditions apply:

(1) The measured pollutant levels are below those used in the original application as listed below:

(i) TCDD Equivalents	1.75 E-7 (lbs/hr)
(ii) Arsenic and Compounds	1.13 E-2 (lbs/hr)
(iii) Beryllium and Compounds	7.35 E-5 (lbs/hr)
(iv) Cadmium and Compounds	1.84 E-2 (lbs/hr)
(v) Nickel and Compounds	0.152 (lbs/hr)
(vi) Hexavalent Chromium and Compounds	4.73 E-3 (lbs/hr)
(vii) Mercury and Compounds	0.325 (lbs/hr)
(viii) Lead and Compounds	0.441 (lbs/hr)

(2) The volumetric flow rate has not significantly increased from the value used in the application, as listed below:

(i) 85,452 SCFM

(3) The stack gas temperature has not significantly decreased from the value used in the application, as listed below:

**SECTION E. Source Group Restrictions.**

(i) 270 degrees Fahrenheit

**# 002 [25 Pa. Code §127.441]****Operating permit terms and conditions.**

(a) In the demonstration of the 95% reduction of HCL emissions, a credit of 20% shall be given for the control of HCL emissions when the dry lime injection system is operating at a minimum dry lime feed rate of 135 lbs/hr with a minimum average blower discharge pressure of 1.4 psig.

(b) In the demonstration of the 90% reduction of SO<sub>2</sub> emissions, a credit of 40% shall be given for the control of SO<sub>2</sub> emissions when the dry lime injection system is operating at a minimum dry lime feed rate of 135 lbs/hr with a minimum average blower discharge pressure of 1.4 psig.

(c) In order to claim the emission reduction credits for SO<sub>2</sub> and/or HCL in paragraph (a) & (b) above, the permittee shall ensure that the lime slurry feed system and/or the lime injection system is operational. The dry lime feed rate and the blower discharge pressure shall be simultaneously monitored on a continuous basis with readings taken every 15 minutes, on a one hour average. At least three (3) valid readings for each parameter shall be taken for any hour in which the credit is claimed.

(d) Visible air contaminants shall not equal or exceed 10% opacity for more than three minutes in any one hour period and must never equal or exceed 30% opacity as determined by a certified observer or as measured by the continuous emissions monitor.

(e) The CO and NO<sub>x</sub> emission limits apply at all times when the wastes are combusted, except during periods of start-up and shut-down. Provided, however, that the duration of start-up or shutdown shall not exceed three (3) hours per occurrence.

Note: Start-up period commences with the introduction of municipal waste to the empty combustor and does not include any warm-up period when the combustor is combusting only a fossil fuel or any other auxiliary fuel, and no municipal waste is being combusted.

Note: Shutdown shall be interpreted as the point at which the chute to the loading hopper of the combustion train is closed, and a period of 30-minutes has passed to allow waste to be emptied from the throat of the feed chute. The permittee will not be required to adhere to the CO and NO<sub>x</sub> emissions standards during shutdown, as long as the duration of the shutdown does not exceed (3) hours per occurrence, before proceeding to either "process down" or to "normal operations".

**II. TESTING REQUIREMENTS.****# 003 [25 Pa. Code §127.441]****Operating permit terms and conditions.**

(a) The permittee shall conduct source tests for the following:

- (1) Particulate matter (TSP and PM<sub>10</sub>)
- (2) PCDD and PCDF (expressed as 2,3,7,8, TCDD equivalents calculated according to the Department's approved method).
- (3) Arsenic and Compounds (expressed as arsenic)
- (4) Beryllium and Compounds (expressed as beryllium)
- (5) Cadmium and Compounds (expressed as cadmium)
- (6) Nickel and Compounds (expressed as nickel)
- (7) Lead and Compounds (expressed as lead)
- (8) Mercury and Compounds (expressed as mercury)
- (9) Hexavalent chromium and compounds (expressed as chromium)
- (10) Hydrogen Chloride

**SECTION E. Source Group Restrictions.**

(b) Unless otherwise approved by DEP in writing, the permittee shall conduct performance testing in accordance with the following schedule:

(1) All pollutants except PCDD/PCDF: Semiannually. Testing may occur annually if the test results are less than 80% of the permitted standard. If a given parameter/unit equals or exceeds 80%, that parameter/unit shall be tested semi-annually for a period of 24-consecutive months until testing demonstrates a result of less than 80% of the permitted standard. The permittee shall notify the Department prior to reverting back to annual testing.

(2) PCDD/PCDF: Annually.

(c) Pursuant to 25 Pa. Code § 139.3 at least 90 calendar days prior to commencing an emissions testing program, unless otherwise approved in writing by DEP, a test protocol shall be submitted to the Department for review and approval. Unless otherwise approved in writing by DEP, the permittee shall not conduct the test that is the subject of the protocol, until the protocol has been approved by DEP.

(d) Pursuant to 25 Pa. Code § 139.3 at least 15 calendar days prior to commencing an emission testing program, notification as to the date and time of testing shall be given to the appropriate Regional Office. Notification shall also be sent to the Division of Source Testing and Monitoring. Notification shall not be made without prior receipt of a protocol acceptance letter from the Department.

(e) Pursuant to 25 Pa. Code Section 139.53(a)(3) within 15 calendar days after completion of the on-site testing portion of an emission test program, if a complete test report has not yet been submitted, an electronic mail notification shall be sent to the Department's Division of Source Testing and Monitoring and the appropriate Regional Office indicating the completion date of the on-site testing.

(f) Pursuant to 40 CFR Part 60.8(a), 40 CFR Part 61.13(f) and 40 CFR Part 63.7(g) a complete test report shall be submitted to the Department no later than 60 calendar days after completion of the on-site testing portion of an emission test program. For those tests being conducted pursuant to 40 CFR Part 61, a complete test report shall be submitted within 31 days after completion of the test

(g) Pursuant to 25 Pa. Code Section 139.53(b) a complete test report shall include a summary of the emission results on the first page of the report indicating if each pollutant measured is within permitted limits and a statement of compliance or non-compliance with all applicable permit conditions. The summary results will include, at a minimum, the following information:

1. A statement that the owner or operator has reviewed the report from the emissions testing body and agrees with the findings.
2. Permit number(s) and condition(s) which are the basis for the evaluation.
3. Summary of results with respect to each applicable permit condition.
4. Statement of compliance or non-compliance with each applicable permit condition.

(h) Pursuant to 25 Pa. Code § 139.3 to all submittals shall meet all applicable requirements specified in the most current version of the Department's Source Testing Manual.

(i) All testing shall be performed in accordance with the provisions of Chapter 139 of the Rules and Regulations of the Department of Environmental Protection.

(j) Pursuant to 25 Pa. Code Section 139.53(a)(1) and 139.53(a)(3) all submittals, besides notifications, shall be accomplished through PSIMS\*Online available through <https://www.depgreenport.state.pa.us/ecommm/Login.jsp> when it becomes available. If internet submittal cannot be accomplished, submittal shall be made as follows:

Regional Office:

Digital copy (only): RA-epsctestesting@pa.gov

Bureau of Air Quality:

Digital copy (only): RA-epstacktesting@pa.gov

**SECTION E. Source Group Restrictions.**

(k) The permittee shall ensure all federal reporting requirements contained in the applicable subpart of 40 CFR are followed, including timelines more stringent than those contained herein. In the event of an inconsistency or any conflicting requirements between state and the federal, the most stringent provision, term, condition, method or rule shall be used by default.

**III. MONITORING REQUIREMENTS.****# 004 [25 Pa. Code §127.511]****Monitoring and related recordkeeping and reporting requirements.**

The permittee shall install, calibrate, maintain and operate a device for measuring on a continuous basis the temperature of the flue gas stream at the inlet to each baghouse. The temperature shall be calculated in 4-hr block arithmetic averages.

**IV. RECORDKEEPING REQUIREMENTS.**

No additional record keeping requirements exist except as provided in other sections of this permit including Section B (Title V General Requirements).

**V. REPORTING REQUIREMENTS.****# 005 [25 Pa. Code §127.441]****Operating permit terms and conditions.**

(a) Data gathered from the continuous monitoring of the drylime feed rate and the blower discharge pressure shall be submitted to the Regional Air Quality Program Manager when requesting credits towards the emissions of HCL or SO<sub>2</sub>. The data shall be retained on-site for at least five years following the date of the record and shall be made available to the Department upon request.

(b) The following information shall be included for each MWC unit in the quarterly submission of reports:

(1) The total weight of the activated carbon delivered to the plant and the estimated quarterly usage of carbon at the facility with supporting calculations.

(2) The average carbon mass feed rate in pounds per hour estimated during the initial mercury performance test and all subsequent annual performance tests with supporting calculations.

(3) The average carbon mass feed rate in pounds per hour estimated during the initial dioxin/furan performance test and all subsequent annual performance tests with supporting calculations.

(4) Identification of the calendar dates when the recorded 8-hour block average carbon mass feed rates in pounds per hour were less than the carbon feed rates estimated during the performance tests for mercury and dioxin/furan emissions.

(5) Carbon injection system operating parameter data for the parameter(s) that are the primary indicator(s) of carbon feed rate(e.g., screw feeder speed).

**VI. WORK PRACTICE REQUIREMENTS.****# 006 [25 Pa. Code §127.441]****Operating permit terms and conditions.**

(a) Large, bulky non-combustibles, difficult to burn, bulky combustible material and visible automotive batteries shall be excluded from the refuse charged to the furnace.

(b) The permittee shall remove, to the greatest extent practical, hazardous materials from the waste to be incinerated.

(c) The permittee may not accept for processing, other than composting, truckloads composed primarily of leaf waste.

(d) The tipping area shall be totally enclosed and operated at a negative pressure to prevent the escape of malodors. The air shall be used as primary combustion air in the incinerator. Outdoor storage of municipal waste is prohibited.

(e) Open topped refuse trucks must be appropriately covered. Any such truck not so equipped shall be denied access by the scale house operator. Notice of this requirement shall be conspicuously posted. Similarly, all haulers of material exiting

**SECTION E. Source Group Restrictions.**

the site shall be required to tarp or otherwise cover thier loads.

(f) Ash shall be loaded in an enclosed area or handled wet in enclosed containers. Ash removal equipment shall be enclosed or installed in an enclosed building.

(g) The tipping floor shall be cleaned at least once every seven days.

(h) Municipal waste as defined in the Department's "BAT Criteria for Municipal Waste Incinerator", of November 9, 1987, and as further defined in 25 Pa. Code Section 75.260(a), or previously approved waste, shall be accepted for processing by the facility.

(i) After the plant ceases operation and until operation resumes, all waste deliveries shall be diverted no later than 72 hours into the downtime. In the event of an unscheduled plant downtime, the Department shall be notified within 24 hours. No later than 120 hours after the plant ceases operation in any downtime, the facility shall commence shipment of all on-site waste to an approved alternate disposal site until normal operations resume.

(j) The permittee shall operate and maintain the Low NOx (LN) Technology on each of the three combustors in accordance with the manufacturer's specifications and with good operating practices.  
do so in accordance with the manufacturer's specifications and with good operating practices.

**VII. ADDITIONAL REQUIREMENTS.**

**# 007 [25 Pa. Code §127.441]**

**Operating permit terms and conditions.**

(a) Charging of waste shall cease in the event that any of the following conditions exists:

(1) The operating temperature drops below 1,600 degrees Fahrenheit for a 15-minute period.

(2) The flue gas oxygen level drops below 3.5% (dry basis) for a 15-minute period.

(3) The opacity of the visible emissions is equal to or greater than 10% for a 15-minute period.

(4) The baghouse inlet temperature exceeds 500 degrees Fahrenheit for a 15 minute period.

(5) Either the forced draft or the induced draft fan fails.

(b) Start-up/standby fuel shall be propane gas.

(c) The auxiliary burners shall be placed in service if the combustion gas temperature drops below 1800 degrees Farenheit. This correlates to a rooftop temperature of 1030 degrees Fahrenheit.

(d) Excess oxygen (O2), as measured between the convection section of the boiler and the economizer or any other suitable location approved by the Department, shall be maintained at or above 3.5% (dry basis), on an hourly average.

(e) Wastes may not be introduced into the combustors until an operating temperature of 1800 degrees Farenheit has been reached and maintained.

(f) When the combustors are in operation, the tipping area shall be maintained at a negative air pressure. The tipping floor air shall be used as primary combustion air.

(g) The temperature in the combustors shall be maintained at a minimum temperature of 1800 degrees Farenheit, on an hourly average, during the combustion of municipal waste or other waste approved by the Department.

(h) A preventative maintenance plan and schedule for those facility components which potentially impact atmospheric emissions, and a fully completed air pollution episode plan must be maintained, to represent facility modifications incorporating the SNCR and the activated carbon injection system. The plan shall identify a spare parts inventory to be maintained on-site.

**SECTION E. Source Group Restrictions.**

(i) The applicants/operator shall provide the Department with access to all CEM read-outs via telephone dial-up (modem) from the Department's computer(s), or other computer-based applications such as a website to display CEM data. It will be the applicant's/operator's responsibility to provide all hardware, software, and funds required to provide this access. The Department shall specify the acquisition configuration.

**\*\*\* Permit Shield in Effect. \*\*\***





**SECTION E. Source Group Restrictions.**

Group Name: G02  
Group Description: Process Silos  
Sources included in this group

ID	Name
004	HYDRATED LIME SILO
005	PEBBLE LIME SILO
008	ACTIVATED CARBON STORAGE SILO

**I. RESTRICTIONS.**

**Emission Restriction(s).**

# 001 [25 Pa. Code §127.441]

**Operating permit terms and conditions.**

Particulate matter emissions from the exhaust of the fabric collectors associated with lime silos, the activated carbon injection system silo, and the ash handling areas, shall be controlled. The permittee may not permit particulate matter emissions into the outdoor atmosphere in excess of 0.02 gr/dscf.

**II. TESTING REQUIREMENTS.**

No additional testing requirements exist except as provided in other sections of this permit including Section B (Title V General Requirements).

**III. MONITORING REQUIREMENTS.**

No additional monitoring requirements exist except as provided in other sections of this permit including Section B (Title V General Requirements).

**IV. RECORDKEEPING REQUIREMENTS.**

No additional record keeping requirements exist except as provided in other sections of this permit including Section B (Title V General Requirements).

**V. REPORTING REQUIREMENTS.**

No additional reporting requirements exist except as provided in other sections of this permit including Section B (Title V General Requirements).

**VI. WORK PRACTICE REQUIREMENTS.**

No additional work practice requirements exist except as provided in other sections of this permit including Section B (Title V General Requirements).

**VII. ADDITIONAL REQUIREMENTS.**

No additional requirements exist except as provided in other sections of this permit including Section B (Title V General Requirements).

**\*\*\* Permit Shield in Effect. \*\*\***

**SECTION E. Source Group Restrictions.**

Group Name: G03

Group Description: 40 CFR Part 63, Subpart ZZZZ

**Sources included in this group**

ID	Name
006	FIRE PUMP DIESEL ENGINE
009	EMERGENCY GENERATOR

**I. RESTRICTIONS.**

No additional requirements exist except as provided in other sections of this permit including Section B (Title V General Requirements).

**II. TESTING REQUIREMENTS.**

No additional testing requirements exist except as provided in other sections of this permit including Section B (Title V General Requirements).

**III. MONITORING REQUIREMENTS.**

No additional monitoring requirements exist except as provided in other sections of this permit including Section B (Title V General Requirements).

**IV. RECORDKEEPING REQUIREMENTS.**

No additional record keeping requirements exist except as provided in other sections of this permit including Section B (Title V General Requirements).

**V. REPORTING REQUIREMENTS.**

No additional reporting requirements exist except as provided in other sections of this permit including Section B (Title V General Requirements).

**VI. WORK PRACTICE REQUIREMENTS.**

No additional work practice requirements exist except as provided in other sections of this permit including Section B (Title V General Requirements).

**VII. ADDITIONAL REQUIREMENTS.****# 001 [40 CFR Part 63 NESHAPS for Source Categories §40 CFR 63.6585]****Subpart ZZZZ - National Emissions Standards for Hazardous Air Pollutants for Stationary Reciprocating Internal Combustion Engines****Am I subject to this subpart?**

§ 63.6585 Am I subject to this subpart?

You are subject to this subpart if you own or operate a stationary RICE at a major or area source of HAP emissions, except if the stationary RICE is being tested at a stationary RICE test cell/stand.

(a) A stationary RICE is any internal combustion engine which uses reciprocating motion to convert heat energy into mechanical work and which is not mobile. Stationary RICE differ from mobile RICE in that a stationary RICE is not a non-road engine as defined at 40 CFR 1068.30, and is not used to propel a motor vehicle or a vehicle used solely for competition.

(b) [NA – NOT A MAJOR HAP SOURCE]

(c) An area source of HAP emissions is a source that is not a major source.

(d) If you are an owner or operator of an area source subject to this subpart, your status as an entity subject to a standard or other requirements under this subpart does not subject you to the obligation to obtain a permit under 40 CFR part 70 or 71, provided you are not required to obtain a permit under 40 CFR 70.3(a) or 40 CFR 71.3(a) for a reason other than your status

**SECTION E. Source Group Restrictions.**

as an area source under this subpart. Notwithstanding the previous sentence, you must continue to comply with the provisions of this subpart as applicable.

(e) [NA – NOT USED FOR NATIONAL SECURITY PURPOSES]

(f) [NA – RICE NOT RESIDENTIAL, COMMERCIAL OR INSTITUTIONAL]

[69 FR 33506, June 15, 2004, as amended at 73 FR 3603, Jan. 18, 2008; 78 FR 6700, Jan. 30, 2013; 87 FR 48607, Aug. 10, 2022]

§ 63.6590 What parts of my plant does this subpart cover?

This subpart applies to each affected source.

(a) Affected source. An affected source is any existing, new, or reconstructed stationary RICE located at a major or area source of HAP emissions, excluding stationary RICE being tested at a stationary RICE test cell/stand.

(1) Existing stationary RICE.

(i) [NA – NOT A MAJOR HAP SOURCE]

(ii) [NA – NOT A MAJOR HAP SOURCE]

(iii) For stationary RICE located at an area source of HAP emissions, a stationary RICE is existing if you commenced construction or reconstruction of the stationary RICE before June 12, 2006.

(iv) A change in ownership of an existing stationary RICE does not make that stationary RICE a new or reconstructed stationary RICE.

(2) New stationary RICE.

(i) [NA – NOT A MAJOR HAP SOURCE]

(ii) [NA – NOT A MAJOR HAP SOURCE]

(iii) [NA – NOT A NEW SOURCE]

(3) [NA – NOT A RECONSTRUCTED SOURCE]

(b) Stationary RICE subject to limited requirements. (1) An affected source which meets either of the criteria in paragraphs (b)(1)(i) through (ii) of this section does not have to meet the requirements of this subpart and of subpart A of this part except for the initial notification requirements of § 63.6645(f).

(i) [NA – NOT A MAJOR HAP SOURCE]

(ii) [NA – NOT A MAJOR HAP SOURCE]

(2) [NA – NOT A MAJOR HAP SOURCE AND DOES NOT COMBUST LFG]

(3) The following stationary RICE do not have to meet the requirements of this subpart and of subpart A of this part, including initial notification requirements:

(i) [NA – NOT A MAJOR HAP SOURCE]

(ii) [NA – NOT A MAJOR HAP SOURCE]

(iii) [NA – NOT A MAJOR HAP SOURCE]

**SECTION E. Source Group Restrictions.**

(iv) [NA – NOT A MAJOR HAP SOURCE]

(v) [NA – NOT A MAJOR HAP SOURCE AND DOES NOT COMBUST LFG]

(c) [NA – NOT SUBJECT TO SUBPARTS IIII OR JJJJ]

[69 FR 33506, June 15, 2004, as amended at 73 FR 3604, Jan. 18, 2008; 75 FR 9674, Mar. 3, 2010; 75 FR 37733, June 30, 2010; 75 FR 51588, Aug. 20, 2010; 78 FR 6700, Jan. 30, 2013; 87 FR 48607, Aug. 10, 2022]

§ 63.6595 When do I have to comply with this subpart?

(a) Affected sources.

(1) (1) [NA - THE AFFECTED DATE FOR THE ABOVE EXISTING EMERGENCY GENERATORS HAS ALREADY PASSED]

(2) [NA – NOT A MAJOR HAP SOURCE]

(3) [NA – NOT A MAJOR HAP SOURCE]

(4) [NA – NOT A MAJOR HAP SOURCE]

(5) [NA – NOT A MAJOR HAP SOURCE]

(6) [NA – NOT SUBJECT TO EMISSION OR OPERATING LIMITATIONS]

(7) [NA – NOT SUBJECT TO EMISSION OR OPERATING LIMITATIONS]

(b) Area sources that become major sources. If you have an area source that increases its emissions or its potential to emit such that it becomes a major source of HAP, the compliance dates in paragraphs (b)(1) and (2) of this section apply to you.

(1) Any stationary RICE for which construction or reconstruction is commenced after the date when your area source becomes a major source of HAP must be in compliance with this subpart upon startup of your affected source.

(2) Any stationary RICE for which construction or reconstruction is commenced before your area source becomes a major source of HAP must be in compliance with the provisions of this subpart that are applicable to RICE located at major sources within 3 years after your area source becomes a major source of HAP.

(c) If you own or operate an affected source, you must meet the applicable notification requirements in § 63.6645 and in 40 CFR part 63, subpart A.

[69 FR 33506, June 15, 2004, as amended at 73 FR 3604, Jan. 18, 2008; 75 FR 9675, Mar. 3, 2010; 75 FR 51589, Aug. 20, 2010; 78 FR 6701, Jan. 30, 2013]

#### Emission and Operating Limitations

§ 63.6600 What emission limitations and operating limitations must I meet if I own or operate a stationary RICE with a site rating of more than 500 brake HP located at a major source of HAP emissions?

[NA – NOT SUBJECT TO EMISSION OR OPERATING LIMITATIONS]

§ 63.6601 What emission limitations must I meet if I own or operate a new or reconstructed 4SLB stationary RICE with a site rating of greater than or equal to 250 brake HP and less than or equal to 500 brake HP located at a major source of HAP emissions?

[NA – NOT SUBJECT TO EMISSION OR OPERATING LIMITATIONS]

[73 FR 3605, Jan. 18, 2008, as amended at 75 FR 9675, Mar. 3, 2010; 75 FR 51589, Aug. 20, 2010]

**SECTION E. Source Group Restrictions.**

§ 63.6602 What emission limitations and other requirements must I meet if I own or operate an existing stationary RICE with a site rating of equal to or less than 500 brake HP located at a major source of HAP emissions?

[NA – NOT SUBJECT TO EMISSION OR OPERATING LIMITATIONS]

§ 63.6603 What emission limitations, operating limitations, and other requirements must I meet if I own or operate an existing stationary RICE located at an area source of HAP emissions?

Compliance with the numerical emission limitations established in this subpart is based on the results of testing the average of three 1-hour runs using the testing requirements and procedures in § 63.6620 and Table 4 to this subpart.

(a) If you own or operate an existing stationary RICE located at an area source of HAP emissions, YOU MUST COMPLY WITH THE REQUIREMENTS IN TABLE 2d to this subpart and the operating limitations in Table 2b to this subpart that apply to you.

TABLE 2d REQUIREMENTS: Item 4

For each EMERGENCY STATIONARY CI RICE and black start stationary CI RICE\*\*, you must meet the following requirement, except during periods of startup:

- a. Change oil and filter every 500 hours of operation within 1 year + 30 days of previous change, whichever comes first.
- b. Inspect air cleaner every 1,000 hours of operation or within 1 year + 30 days, whichever comes first, and replace as necessary;
- c. Inspect all hoses and belts every 500 hours of operation or 1 year + 30 days, whichever comes first, and replace as necessary.

TABLE 2d REQUIREMENTS: Item 5

For each EMERGENCY STATIONARY SI RICE; black start stationary SI RICE; non-emergency, non-black start 4SLB stationary RICE >500 HP that operate 24 hours or less per calendar year; non-emergency, non-black start 4SRB stationary RICE >500 HP that operate 24 hours or less per calendar year\*\*, you must meet the following requirement, except during periods of startup:

- a. Change oil and filter every 500 hours of operation or 1 year + 30 days, whichever comes first.
- b. Inspect spark plugs every 1,000 hours of operation or 1 year + 30 days, whichever comes first, and replace as necessary;
- c. Inspect all hoses and belts every 500 hours of operation or 1 year + 30 days, whichever comes first, and replace as necessary.

Note 1: Sources have the option to utilize an oil analysis program as described in § 63.6625(i) or (j) in order to extend the specified oil change requirement in table 2d of this subpart.

Note 2: During periods of startup you must minimize the engine's time spent at idle and minimize the engine's startup time at startup to a period needed for appropriate and safe loading of the engine, not to exceed 30 minutes, after which time the non-startup emission limitations apply.

Note 3: If an emergency engine is operating during an emergency and it is not possible to shut down the engine in order to perform the management practice requirements on the schedule required in table 2d of this subpart, or if performing the management practice on the required schedule would otherwise pose an unacceptable risk under Federal, state, or local law, the management practice can be delayed until the emergency is over or the unacceptable risk under Federal, state, or local law has abated. The management practice should be performed as soon as practicable after the emergency has ended or the unacceptable risk under Federal, state, or local law has abated. Sources must report any failure to perform the management practice on the schedule required and the Federal, state or local law under which the risk was deemed unacceptable.

**SECTION E. Source Group Restrictions.**

[END OF TABLE 2d REQUIREMENTS]

(b) thru (f) [NA – EMERGENCY ENGINE(S)]

[75 FR 9675, Mar. 3, 2010, as amended at 75 FR 51589, Aug. 20, 2010; 76 FR 12866, Mar. 9, 2011; 78 FR 6701, Jan. 30, 2013; 89 FR 70515, Aug. 30, 2024]

§ 63.6604 What fuel requirements must I meet if I own or operate a stationary CI RICE?

(a) [NA – EMERGENCY ENGINE(S)]

(b) Beginning January 1, 2015, if you own or operate an existing emergency CI stationary RICE with a site rating of more than 100 brake HP and a displacement of less than 30 liters per cylinder that uses diesel fuel and operates or is contractually obligated to be available for more than 15 hours per calendar year for the purposes specified in §63.6640(f)(2)(ii) and (iii) or that operates for the purpose specified in §63.6640(f)(4)(ii), you must use diesel fuel that meets the requirements in 40 CFR 1090.305 for nonroad diesel fuel, except that any existing diesel fuel purchased (or otherwise obtained) prior to January 1, 2015, may be used until depleted

(c) [RESERVED]

(d) [NA – NOT IN SPECIFIED GEOGRAPHIC LOCATIONS]

[78 FR 6702, Jan. 30, 2013, as amended at 85 FR 78463, Dec. 4, 2020; 87 FR 48607, Aug. 10, 2022]

General Compliance Requirements

§ 63.6605 What are my general requirements for complying with this subpart?

(a) You must be in compliance with the emission limitations, operating limitations, and other requirements in this subpart that apply to you at all times.

(b) At all times you must operate and maintain any affected source, including associated air pollution control equipment and monitoring equipment, in a manner consistent with safety and good air pollution control practices for minimizing emissions. The general duty to minimize emissions does not require you to make any further efforts to reduce emissions if levels required by this standard have been achieved. Determination of whether such operation and maintenance procedures are being used will be based on information available to the Administrator which may include, but is not limited to, monitoring results, review of operation and maintenance procedures, review of operation and maintenance records, and inspection of the source.

[75 FR 9675, Mar. 3, 2010, as amended at 78 FR 6702, Jan. 30, 2013]

Testing and Initial Compliance Requirements

§ 63.6610 By what date must I conduct the initial performance tests or other initial compliance demonstrations if I own or operate a stationary RICE with a site rating of more than 500 brake HP located at a major source of HAP emissions?

[NA – NOT A MAJOR HAP SOURCE]

§ 63.6611 By what date must I conduct the initial performance tests or other initial compliance demonstrations if I own or operate a new or reconstructed 4SLB SI stationary RICE with a site rating of greater than or equal to 250 and less than or equal to 500 brake HP located at a major source of HAP emissions?

[NA – NOT A MAJOR HAP SOURCE]

[73 FR 3605, Jan. 18, 2008, as amended at 75 FR 51589, Aug. 20, 2010]

§ 63.6612 By what date must I conduct the initial performance tests or other initial compliance demonstrations if I own or

**SECTION E. Source Group Restrictions.**

operate an existing stationary RICE with a site rating of less than or equal to 500 brake HP located at a major source of HAP emissions or an existing stationary RICE located at an area source of HAP emissions?

(a) [NA – NO PERFORMANCE TESTING REQUIRED]

(b) [PER TABLES 4 AND 5, NO TESTING APPLIES TO EMERGENCY ENGINES]

[75 FR 9676, Mar. 3, 2010, as amended at 75 FR 51589, Aug. 20, 2010]

§ 63.6615 When must I conduct subsequent performance tests?

[NA – NOT SUBJECT TO EMISSION OR OPERATING LIMITATIONS]

§ 63.6620 What performance tests and other procedures must I use?

[NA – NO PERFORMANCE TESTING REQUIRED]

[69 FR 33506, June 15, 2004, as amended at 75 FR 9676, Mar. 3, 2010; 78 FR 6702, Jan. 30, 2013; 89 FR 70516, Aug. 30, 2024]

§ 63.6625 What are my monitoring, installation, collection, operation, and maintenance requirements?

(a) [NA – CEMS NOT REQUIRED]

(b) [NA – CPMS NOT REQUIRED]

(c) [NA – LFG NOT USED]

(d) [NA – NOT A MAJOR HAP SOURCE]

(e) If you own or operate any of the following stationary RICE, you must operate and maintain the stationary RICE and after-treatment control device (if any) according to the manufacturer's emission-related written instructions or develop your own maintenance plan which must provide to the extent practicable for the maintenance and operation of the engine in a manner consistent with good air pollution control practice for minimizing emissions:

(1) [NA – NOT A MAJOR HAP SOURCE]

(2) [NA – NOT A MAJOR HAP SOURCE]

(3) An existing emergency or black start stationary RICE located at an area source of HAP emissions;

(4) thru (10) [NA – EMERGENCY ENGINE(S)]

(f) If you own or operate an existing emergency stationary RICE with a site rating of less than or equal to 500 brake HP located at a major source of HAP emissions or an existing emergency stationary RICE located at an area source of HAP emissions, you must install a non-resettable hour meter if one is not already installed.

(g) [NA – EMERGENCY ENGINE(S)]

(h) If you operate a new, reconstructed, or existing stationary engine, you must minimize the engine's time spent at idle during startup and minimize the engine's startup time to a period needed for appropriate and safe loading of the engine, not to exceed 30 minutes, after which time the emission standards applicable to all times other than startup in Tables 1a, 2a, 2c, and 2d to this subpart apply. [NOTE: ONLY TABLE 2d APPLIES]

(i) If you own or operate a stationary CI engine that is subject to the work, operation or management practices in items 1 or 2 of Table 2c to this subpart or in items 1 or 4 of Table 2d to this subpart, you have the option of utilizing an oil analysis program in order to extend the specified oil change requirement in Tables 2c and 2d to this subpart. The oil analysis must

**SECTION E. Source Group Restrictions.**

be performed at the same frequency specified for changing the oil in Table 2c or 2d to this subpart. The analysis program must at a minimum analyze the following three parameters: Total Base Number, viscosity, and percent water content. The condemning limits for these parameters are as follows: Total Base Number is less than 30 percent of the Total Base Number of the oil when new; viscosity of the oil has changed by more than 20 percent from the viscosity of the oil when new; or percent water content (by volume) is greater than 0.5. If all of these condemning limits are not exceeded, the engine owner or operator is not required to change the oil. If any of the limits are exceeded, the engine owner or operator must change the oil within 2 business days of receiving the results of the analysis; if the engine is not in operation when the results of the analysis are received, the engine owner or operator must change the oil within 2 business days or before commencing operation, whichever is later. The owner or operator must keep records of the parameters that are analyzed as part of the program, the results of the analysis, and the oil changes for the engine. The analysis program must be part of the maintenance plan for the engine.

(j) If you own or operate a stationary SI engine that is subject to the work, operation or management practices in items 6, 7, or 8 of Table 2c to this subpart or in items 5, 6, 7, 9, or 11 of Table 2d to this subpart, you have the option of utilizing an oil analysis program in order to extend the specified oil change requirement in Tables 2c and 2d to this subpart. The oil analysis must be performed at the same frequency specified for changing the oil in Table 2c or 2d to this subpart. The analysis program must at a minimum analyze the following three parameters: Total Acid Number, viscosity, and percent water content. The condemning limits for these parameters are as follows: Total Acid Number increases by more than 3.0 milligrams of potassium hydroxide (KOH) per gram from Total Acid Number of the oil when new; viscosity of the oil has changed by more than 20 percent from the viscosity of the oil when new; or percent water content (by volume) is greater than 0.5. If all of these condemning limits are not exceeded, the engine owner or operator is not required to change the oil. If any of the limits are exceeded, the engine owner or operator must change the oil within 2 business days of receiving the results of the analysis; if the engine is not in operation when the results of the analysis are received, the engine owner or operator must change the oil within 2 business days or before commencing operation, whichever is later. The owner or operator must keep records of the parameters that are analyzed as part of the program, the results of the analysis, and the oil changes for the engine. The analysis program must be part of the maintenance plan for the engine.

[69 FR 33506, June 15, 2004, as amended at 73 FR 3606, Jan. 18, 2008; 75 FR 9676, Mar. 3, 2010; 75 FR 51589, Aug. 20, 2010; 76 FR 12866, Mar. 9, 2011; 78 FR 6703, Jan. 30, 2013; 89 FR 70516, Aug. 30, 2024]

§ 63.6630 How do I demonstrate initial compliance with the emission limitations, operating limitations, and other requirements?

(a) You must demonstrate initial compliance with each emission limitation, operating limitation, and other requirement that applies to you according to Table 5 of this subpart. [NA – NONE OF THE CATEGORIES IN TABLE 5 APPLY TO EMERGENCY ENGINES]

(b) [NA – PERFORMANCE TESTING NOT REQUIRED]

(c) [NA – NOCS NOT REQUIRED FOR EXISTING EMERGENCY RICE]

(d) [NA – EMERGENCY ENGINE(S)]

(e) [NA – EMERGENCY ENGINE(S)]

[69 FR 33506, June 15, 2004, as amended at 78 FR 6704, Jan. 30, 2013]

Continuous Compliance Requirements

§ 63.6635 How do I monitor and collect data to demonstrate continuous compliance?

[NA – NOT SUBJECT TO EMISSION OR OPERATING LIMITATIONS]

[69 FR 33506, June 15, 2004, as amended at 76 FR 12867, Mar. 9, 2011]

§ 63.6640 How do I demonstrate continuous compliance with the emission limitations, operating limitations, and other requirements?



**SECTION E. Source Group Restrictions.**

(a) You must demonstrate continuous compliance with each emission limitation, operating limitation, and other requirements in Tables 1a and 1b, Tables 2a and 2b, Table 2c, and Table 2d to this subpart that apply to you [NOTE: ONLY TABLE 2d APPLIES] according to methods specified in Table 6 to this subpart.

**TABLE 6 REQUIREMENTS: Item 9**

For each existing emergency and black start stationary RICE located at an area source of HAP, complying with the requirement to "Work or Management practices", you must demonstrate continuous compliance by:

- i. Operating and maintaining the stationary RICE according to the manufacturer's emission-related operation and maintenance instructions; or
- ii. Develop and follow your own maintenance plan which must provide to the extent practicable for the maintenance and operation of the engine in a manner consistent with good air pollution control practice for minimizing emissions.

[END OF TABLE 6 REQUIREMENTS]

(b) [NA – NOT SUBJECT TO EMISSION OR OPERATING LIMITATIONS]

(c) [NA – ANNUAL COMPLIANCE DEMONSTRATION NOT REQUIRED]

(d) [NA – NOT SUBJECT TO EMISSION OR OPERATING LIMITATIONS]

(e) You must also report each instance in which you did not meet the requirements in Table 8 to this subpart that apply to you. If you own or operate a new or reconstructed stationary RICE with a site rating of less than or equal to 500 brake HP located at a major source of HAP emissions (except new or reconstructed 4SLB engines greater than or equal to 250 and less than or equal to 500 brake HP), a new or reconstructed stationary RICE located at an area source of HAP emissions, or any of the following RICE with a site rating of more than 500 brake HP located at a major source of HAP emissions, you do not need to comply with the requirements in Table 8 to this subpart: An existing 2SLB stationary RICE, an existing 4SLB stationary RICE, an existing emergency stationary RICE, an existing limited use stationary RICE, or an existing stationary RICE which fires landfill gas or digester gas equivalent to 10 percent or more of the gross heat input on an annual basis. If you own or operate any of the following RICE with a site rating of more than 500 brake HP located at a major source of HAP emissions, you do not need to comply with the requirements in Table 8 to this subpart, except for the initial notification requirements: a new or reconstructed stationary RICE that combusts landfill gas or digester gas equivalent to 10 percent or more of the gross heat input on an annual basis, a new or reconstructed emergency stationary RICE, or a new or reconstructed limited use stationary RICE. [EXISTING EMERGENCY RICE AT AREA HAP SOURCES ARE NOT AMONG THOSE EXEMPTED FROM THIS SECTION]

(f) If you own or operate an emergency stationary RICE, you must operate the emergency stationary RICE according to the requirements in paragraphs (f)(1) through (4) of this section. In order for the engine to be considered an emergency stationary RICE under this subpart, any operation other than emergency operation, maintenance and testing, and operation in non-emergency situations for 50 hours per year, as described in paragraphs (f)(1) through (4), is prohibited. If you do not operate the engine according to the requirements in paragraphs (f)(1) through (4), the engine will not be considered an emergency engine under this subpart and must meet all requirements for non-emergency engines.

(1) There is no time limit on the use of emergency stationary RICE in emergency situations.

(2) You may operate your emergency stationary RICE for the purpose specified in paragraph (f)(2)(i) of this section for a maximum of 100 hours per calendar year. Any operation for non-emergency situations as allowed by paragraphs (f)(3) and (4) of this section counts as part of the 100 hours per calendar year allowed by this paragraph (f)(2).

(i) Emergency stationary RICE may be operated for maintenance checks and readiness testing, provided that the tests are recommended by federal, state or local government, the manufacturer, the vendor, the regional transmission organization or equivalent balancing authority and transmission operator, or the insurance company associated with the engine. The owner or operator may petition the Administrator for approval of additional hours to be used for maintenance checks and readiness testing, but a petition is not required if the owner or operator maintains records indicating that federal, state, or local standards require maintenance and testing of emergency RICE beyond 100 hours per calendar year.

**SECTION E. Source Group Restrictions.**

(ii)-(iii) [RESERVED]

(3) [NA – NOT A MAJOR HAP SOURCE]

(4) Emergency stationary RICE located at area sources of HAP may be operated for up to 50 hours per calendar year in non-emergency situations. The 50 hours of operation in non-emergency situations are counted as part of the 100 hours per calendar year for maintenance and testing provided in paragraph (f)(2) of this section. Except as provided in paragraphs (f)(4)(i) and (ii) of this section, the 50 hours per year for non-emergency situations cannot be used for peak shaving or non-emergency demand response, or to generate income for a facility to an electric grid or otherwise supply power as part of a financial arrangement with another entity.

(i) Prior to May 3, 2014, the 50 hours per year for non-emergency situations can be used for peak shaving or non-emergency demand response to generate income for a facility, or to otherwise supply power as part of a financial arrangement with another entity if the engine is operated as part of a peak shaving (load management program) with the local distribution system operator and the power is provided only to the facility itself or to support the local distribution system.

(ii) The 50 hours per year for non-emergency situations can be used to supply power as part of a financial arrangement with another entity if all of the following conditions are met:

(A) The engine is dispatched by the local balancing authority or local transmission and distribution system operator.

(B) The dispatch is intended to mitigate local transmission and/or distribution limitations so as to avert potential voltage collapse or line overloads that could lead to the interruption of power supply in a local area or region.

(C) The dispatch follows reliability, emergency operation or similar protocols that follow specific NERC, regional, state, public utility commission or local standards or guidelines.

(D) The power is provided only to the facility itself or to support the local transmission and distribution system.

(E) The owner or operator identifies and records the entity that dispatches the engine and the specific NERC, regional, state, public utility commission or local standards or guidelines that are being followed for dispatching the engine. The local balancing authority or local transmission and distribution system operator may keep these records on behalf of the engine owner or operator.

[69 FR 33506, June 15, 2004, as amended at 71 FR 20467, Apr. 20, 2006; 73 FR 3606, Jan. 18, 2008; 75 FR 9676, Mar. 3, 2010; 75 FR 51591, Aug. 20, 2010; 78 FR 6704, Jan. 30, 2013; 87 FR 48607, Aug. 10, 2022]

Notifications, Reports, and Records

§ 63.6645 What notifications must I submit and when?

(a) You must submit all of the notifications in §§63.7(b) and (c), 63.8(e), (f)(4) and (f)(6), 63.9(b) through (e), and (g) and (h) that apply to you by the dates specified if you own or operate any of the following;

(1) [NA – NOT A MAJOR HAP SOURCE]

(2) An existing stationary RICE located at an area source of HAP emissions.

(3) [NA – NOT A MAJOR HAP SOURCE]

(4) [NA – NOT A MAJOR HAP SOURCE]

(5) THIS REQUIREMENT DOES NOT APPLY IF YOU OWN OR OPERATE an existing stationary RICE less than 100 HP, AN EXISTING STATIONARY EMERGENCY RICE, OR AN EXISTING STATIONARY RICE THAT IS NOT SUBJECT TO ANY NUMERICAL EMISSION STANDARDS.

(b) thru (f) [NA – NOT A MAJOR HAP SOURCE]

**SECTION E. Source Group Restrictions.**

(g) [NA – PERFORMANCE TEST NOT REQUIRED]

(h) [NA – PERFORMANCE TEST NOT REQUIRED]

(i) [NA – EMERGENCY ENGINE(S)]

[73 FR 3606, Jan. 18, 2008, as amended at 75 FR 9677, Mar. 3, 2010; 75 FR 51591, Aug. 20, 2010; 78 FR 6705, Jan. 30, 2013; 85 FR 73912, Nov. 19, 2020; 89 FR 70516, Aug. 30, 2024]

§ 63.6650 What reports must I submit and when?

(a) You must submit each report in Table 7 of this subpart that applies to you.

TABLE 7 REQUIREMENTS: Item 4

For each emergency stationary RICE that operate for the purposes specified in § 63.6640(f)(4)(ii), you must submit a Report. The report must contain the information in § 63.6650(h)(1). You must submit the report annually according to the requirements in § 63.6650(h)(2)-(3), and (i).

[END OF TABLE 7 REQUIREMENTS]

(b) Unless the Administrator has approved a different schedule for submission of reports under § 63.10(a), you must submit each report by the date in Table 7 of this subpart and according to the requirements in paragraphs (b)(1) through (b)(9) of this section.

(1) THRU (9) [NA – ANNUAL REPORT REQUIRED ONLY FOR THE PURPOSE AS SPECIFIED IN § 63.6640(f)(4)(ii)]

(c) [NA – “COMPLIANCE REPORT” NOT REQUIRED]

(d) [NA – NOT SUBJECT TO EMISSION OR OPERATING LIMITATIONS]

(e) [NA – NOT SUBJECT TO EMISSION OR OPERATING LIMITATIONS]

(f) [NA – NOT SUBJECT TO TITLE V PERMITTING]

(g) [NA – LFG NOT USED]

(h) If you own or operate an emergency stationary RICE with a site rating of more than 100 brake HP that operates or is contractually obligated to be available for more than 15 hours per calendar year for the purposes specified in § 63.6640(f)(2)(ii) and (iii) or that operates for the purpose specified in § 63.6640(f)(4)(ii), you must submit an annual report according to the requirements in paragraphs (h)(1) through (3) of this section.

(1) The report must contain the following information:

(i) Company name and address where the engine is located.

(ii) Date of the report and beginning and ending dates of the reporting period.

(iii) Engine site rating in brake HP, year construction of the engine commenced (as defined in § 63.2, where the exact year is not known, provide the best estimate), and type of engine (CI, SI 2SLB, SI 4SLB, or SI 4SRB).

(iv) Latitude and longitude of the engine in decimal degrees reported to the fifth decimal place..

(v)-(vi) [Reserved].

(vii) Hours spent for operation for the purpose specified in § 63.6640(f)(4)(ii), including the date, start time, and end time for engine operation for the purposes specified in § 63.6640(f)(4)(ii). The report must also identify the entity that dispatched the

**SECTION E. Source Group Restrictions.**

engine and the situation that necessitated the dispatch of the engine.

(viii) If there were no deviations from the fuel requirements in § 63.6604 that apply to the engine (if any), a statement that there were no deviations from the fuel requirements during the reporting period.

(ix) If there were deviations from the fuel requirements in § 63.6604 that apply to the engine (if any), information on the number, duration (in hours), and cause of deviations, and the corrective action taken.

(2) The first annual report must cover the calendar year 2015 and must be submitted no later than March 31, 2016. Subsequent annual reports for each calendar year must be submitted no later than March 31 of the following calendar year.

(3) Before February 26, 2025, the annual report must be submitted electronically using the subpart specific reporting form in the Compliance and Emissions Data Reporting Interface (CEDRI) that is accessed through EPA's Central Data Exchange (CDX) (<https://cdx.epa.gov/>). However, if the reporting form specific to this subpart is not available in CEDRI at the time that the report is due, the written report must be submitted to the Administrator at the appropriate address listed in § 63.13. Beginning on February 26, 2025, the annual report must be submitted according to paragraph (i) of this section.

(i) Beginning on February 26, 2025 for the annual report specified in § 63.6650(h) and February 26, 2025 or one year after the report becomes available in CEDRI, whichever is later for all other semiannual or annual reports, submit all semiannual and annual subsequent compliance reports using the appropriate electronic report template on the CEDRI website (<https://www.epa.gov/electronic-reporting-air-emissions/cedri>) for this subpart and following the procedure specified in § 63.9(k), except any CBI must be submitted according to the procedures in § 63.6645(h). The date report templates become available will be listed on the CEDRI website. Unless the Administrator or delegated state agency or other authority has approved a different schedule for submission of reports, the report must be submitted by the deadline specified in this subpart, regardless of the method in which the report is submitted.

[69 FR 33506, June 15, 2004, as amended at 75 FR 9677, Mar. 3, 2010; 78 FR 6705, Jan. 30, 2013; 87 FR 48607, Aug. 10, 2022; 89 FR 70517, Aug. 30, 2024]

§ 63.6655 What records must I keep?

(a) [NA – NOT SUBJECT TO EMISSION OR OPERATING LIMITATIONS]

(b) [NA – NO CEMS OR CPMS]

(c) [NA – LFG NOT USED]

(d) [NA – NOT SUBJECT TO EMISSION OR OPERATING LIMITATIONS]

(e) You must keep records of the maintenance conducted on the stationary RICE in order to demonstrate that you operated and maintained the stationary RICE and after-treatment control device (if any) according to your own maintenance plan if you own or operate any of the following stationary RICE;

(1) [NA – NOT A MAJOR HAP SOURCE]

(2) An existing stationary emergency RICE.

(3) An existing stationary RICE located at an area source of HAP emissions subject to management practices as shown in Table 2d to this subpart.

(f) If you own or operate any of the stationary RICE in paragraphs (f)(1) through (2) of this section, you must keep records of the hours of operation of the engine that is recorded through the non-resettable hour meter. The owner or operator must document how many hours are spent for emergency operation, including what classified the operation as emergency and how many hours are spent for non-emergency operation. If the engine is used for the purposes specified in § 63.6640(f)(2)(ii) or (iii) or § 63.6640(f)(4)(ii), the owner or operator must keep records of the notification of the emergency situation, and the date, start time, and end time of engine operation for these purposes.

**SECTION E. Source Group Restrictions.**

(1) [NA – NOT A MAJOR HAP SOURCE]

(2) An existing emergency stationary RICE located at an area source of HAP emissions that does not meet the standards applicable to non-emergency engines.

[69 FR 33506, June 15, 2004, as amended at 75 FR 9678, Mar. 3, 2010; 75 FR 51592, Aug. 20, 2010; 78 FR 6706, Jan. 30, 2013; 87 FR 48607, Aug. 10, 2022; 89 FR 70518, Aug. 30, 2024]

§ 63.6660 In what form and how long must I keep my records?

(a) Your records must be in a form suitable and readily available for expeditious review according to § 63.10(b)(1).

(b) As specified in § 63.10(b)(1), you must keep each record for 5 years following the date of each occurrence, measurement, maintenance, corrective action, report, or record.

(c) You must keep each record readily accessible in hard copy or electronic form for at least 5 years after the date of each occurrence, measurement, maintenance, corrective action, report, or record, according to § 63.10(b)(1).

[69 FR 33506, June 15, 2004, as amended at 75 FR 9678, Mar. 3, 2010]

#### Other Requirements and Information

§ 63.6665 What parts of the General Provisions apply to me?

Table 8 to this subpart shows which parts of the General Provisions in §§ 63.1 through 63.15 apply to you. If you own or operate a new or reconstructed stationary RICE with a site rating of less than or equal to 500 brake HP located at a major source of HAP emissions (except new or reconstructed 4SLB engines greater than or equal to 250 and less than or equal to 500 brake HP), a new or reconstructed stationary RICE located at an area source of HAP emissions, or any of the following RICE with a site rating of more than 500 brake HP located at a major source of HAP emissions, you do not need to comply with any of the requirements of the General Provisions specified in Table 8: An existing 2SLB stationary RICE, an existing 4SLB stationary RICE, an existing stationary RICE that combusts landfill or digester gas equivalent to 10 percent or more of the gross heat input on an annual basis, an existing emergency stationary RICE, or an existing limited use stationary RICE. If you own or operate any of the following RICE with a site rating of more than 500 brake HP located at a major source of HAP emissions, you do not need to comply with the requirements in the General Provisions specified in Table 8 except for the initial notification requirements: A new stationary RICE that combusts landfill gas or digester gas equivalent to 10 percent or more of the gross heat input on an annual basis, a new emergency stationary RICE, or a new limited use stationary RICE. [EXISTING EMERGENCY RICE AT AREA HAP SOURCES ARE NOT AMONG THOSE EXEMPTED FROM THIS SECTION]

[75 FR 9678, Mar. 3, 2010]

#### Reporting Requirements & Regulatory Changes:

Individual sources within this source group that are subject to 40 CFR Part 63 Subpart ZZZZ -National Emissions Standards for Hazardous Air Pollutants for Stationary Reciprocating Internal Combustion Engines shall comply with all applicable requirements of the Subpart. 40 CFR 63.13(a) requires submission of copies of all requests, reports and other communications to both the Department and the EPA. The EPA copies shall be forwarded to:

United States Environmental Protection Agency  
Region III, Air and Radiation Division  
Permits Branch (3AD10)  
Four Penn Center  
1600 John F. Kennedy Boulevard  
Philadelphia, Pennsylvania 19103-2852

Unless otherwise approved by DEP, the DEP copies shall be reported through the Department's Greenport PUP system available through: <https://greenport.pa.gov/ePermitPublicAccess/PublicSubmission/Home>

**SECTION E. Source Group Restrictions.**

In the event that the Federal Subpart that is the subject of this Source Group is revised, the permittee shall comply with the revised version of the subpart, and shall not be required to comply with any provisions in this permit designated as having the subpart as their authority, to the extent that such permit provisions would be inconsistent with the applicable provisions of the revised subpart.

**\*\*\* Permit Shield in Effect. \*\*\***

**SECTION E. Source Group Restrictions.**

Group Name: G04

Group Description: 40 CFR Part 60, Subpart Cb Requirements

Sources included in this group

ID	Name
001	MW COMBUSTOR 1
002	MW COMBUSTOR 2
003	MW COMBUSTOR 3

**I. RESTRICTIONS.****Emission Restriction(s).****# 001 [40 CFR Part 60 Standards of Performance for New Stationary Sources §40 CFR 60.33b]****Subpart Cb - Emission Guidelines and Compliance Schedules for Municipal Waste Combustors****Emission guidelines for municipal waste combustor metals, acid gases, organics, and nitrogen oxides.**

60.33b(a) - The emission limits for municipal waste combustor metals are specified in paragraphs (a)(1) through (a)(3) of this section.

60.33b(a)(1) - The emission limits for particulate matter and opacity shall be at least as protective as the emission limits for particulate matter and opacity as specified in paragraphs (a)(1)(i) through (a)(1)(iii) of this section.

**Particulate Matter Limits (TSP, PM10)**

60.33b(a)(1)(i) - The emission limit for total suspended particulate matter (TSP) and particulate matter (PM10) contained in the gases discharged to the atmosphere from each of the facility's combustors is (0.012) & (0.010) grains per dry standard cubic foot, respectively, each corrected to 7 percent oxygen, dry basis (filterable particulate - EPA Method 5 & 201A).

Note: The above emission limits are derived from the Department's BAT for Municipal Waste incinerators and are more stringent than and supersedes the limit as defined in this subpart.

60.33b(a)(1)(ii) - [Reserved]

**Opacity Limit**

60.33b(a)(1)(iii) - The emission limit for opacity exhibited by the gases discharged to the atmosphere from a designated facility is 10 percent (6-minute average).

60.33b(a)(2) - The emission limits for cadmium shall be at least as protective as the emission limits for cadmium as specified in paragraphs (a)(2)(i) through (a)(2)(ii) of this section.

**Cadmium Limit**

60.33b(a)(2)(i) - The emission limit for cadmium contained in the gases discharged to the atmosphere from each of the facility's combustors is 40 micrograms per dry standard cubic meter, corrected to 7 percent oxygen.

60.33b(a)(2)(ii) - [Reserved]

**Mercury Limit**

60.33b(a)(3) - The emission limit for mercury contained in the gases discharged to the atmosphere from each of the facility's combustors is 50 micrograms per dry standard cubic meter or 85-percent reduction by weight, corrected to 7 percent oxygen, whichever is less stringent.

**Lead Limit**

60.33b(a)(4) - The emission limit for lead contained in the gases discharged to the atmosphere from each of the facility's combustors is 400 micrograms per dry standard cubic meter, corrected to 7 percent oxygen.

**SECTION E. Source Group Restrictions.**

60.33b(b) - The emission limits for municipal waste combustor acid gases, expressed as sulfur dioxide and hydrogen chloride, are specified in paragraphs (b)(1) and (b)(2) of this section.

60.33b(b)(1) - The emission limits for sulfur dioxide shall be at least as protective as the emission limits for sulfur dioxide specified in paragraphs (b)(1)(i) and (b)(1)(ii) of this section.

**Sulfur Limits**

60.33b(b)(1)(i) - The emission limit for sulfur dioxide contained in the gases discharged to the atmosphere from each of the facility's combustors is 30 ppm on an hourly basis and 29 ppm on a 3-hour block basis or 90 percent reduction (by weight) on an 8-hour block average, corrected to 7 percent oxygen (dry basis), whichever is less stringent.

Note: The above emission limit is derived from the Department's BAT for Municipal Waste incinerators and is more stringent than and supersedes the limit as defined in this subpart.

60.33b(b)(1)(ii) - [Reserved]

60.33b(b)(2) - The emission limits for hydrogen chloride shall be at least as protective as the emission limits for hydrogen chloride as specified in paragraphs (b)(2)(i) and (b)(2)(ii) of this section.

**HCl Limit**

60.33b(b)(2)(i) - The emission limit for hydrogen chloride contained in the gases discharged to the atmosphere from a designated facility is 25 ppm by volume on a 24-hour daily arithmetic average or 95-percent reduction by weight or volume on a 24-hour daily arithmetic average, corrected to 7 percent oxygen (dry basis), whichever is less stringent.

Note: The above emission limit is derived from the Department's BAT for Municipal Waste incinerators and is more stringent than and supersedes the limit as defined in this subpart.

60.33b(b)(2)(ii) - [Reserved]

60.33b(b)(3) - [See 60.33b(b)(1)(i) and 60.33b(b)(2)(i)].

60.33b(c) - The emission limits for municipal waste combustor organics, expressed as total mass dioxin/furan, are specified in paragraphs (c)(1) and (c)(2) of this section.

60.33b(c)(1) - The emission limit for (Total) dioxin/furan contained in the gases discharged to the atmosphere from a designated facility at least as protective as the emission limit for dioxin/furan specified in paragraphs (c)(1)(i), (c)(1)(ii), and (c)(1)(iii) of this section, as applicable.

60.33b(c)(1)(i) - N/A (This limit has been superseded by Section 60.33b (c)(1)(iii)).

60.33b(c)(1)(ii) - N/A (Facility does not use an ESP).

**Dioxin/Furan Limit**

60.33b(c)(1)(iii) - The emission limit for designated facilities that do not employ an electrostatic precipitator-based emission control system is 30 nanograms per dry standard cubic meter (total mass), corrected to 7 percent oxygen. In accordance with the Department's BAT requirements the facility is also required to meet a limit of 2.0ng/Nm<sup>3</sup> (at 7%O<sub>2</sub>, dry basis).

**Nitrogen Oxide Limit**

60.33b(d) - The emission limits for nitrogen oxides shall be at least as protective as the emission limits as listed in Table 1 of this subpart. The emission limit for Nitrogen Oxides contained in the gases discharged to the atmosphere from each of the facility's combustors is 180 ppm by volume, corrected to 7 percent oxygen (dry basis), on a 24-hour daily arithmetic average.



**SECTION E. Source Group Restrictions.**

Note: The above emission limit is derived from the Department's BAT for Municipal Waste incinerators and is more stringent than and supersedes the limit as defined in this subpart.

60.33b(d)(1) - N/A (Facility is not involved in NOx emission averaging).

60.33b(d)(2) - N/A (Facility is not involved in the trading of NOx emission credits).

60.33b(d)(3) - N/A (Facility has no fluidized bed combustors).

60 FR 65415, Dec. 19, 1995, as amended at 62 FR 45119, 45125, Aug. 25, 1997; 71 FR 27333, May 10, 2006]

**# 002 [40 CFR Part 60 Standards of Performance for New Stationary Sources §40 CFR 60.36b]**

**Subpart Cb - Emission Guidelines and Compliance Schedules for Municipal Waste Combustors  
Emission guidelines for municipal waste combustor fugitive ash emissions.**

The requirements for municipal waste combustor fugitive ash emissions shall be at least as protective as those requirements listed below and stated in §60.55b of subpart Eb of this part.

60.55b(a) The permittee shall not allow to be discharged to the atmosphere visible emissions of combustion ash from an ash conveying system (including conveyor transfer points) in excess of 5 percent of the observation period (i.e., 9 minutes per 3-hour period), as determined by EPA Reference Method 22 observations as specified in §60.58b(k), except as provided in paragraphs (b) and (c) of this section.

60.55b(b) - The emission limit specified in paragraph (a) of this section does not cover visible emissions discharged inside buildings or enclosures of ash conveying systems; however, the emission limit specified in paragraph (a) of this section does cover visible emissions discharged to the atmosphere from buildings or enclosures of ash conveying systems.

60.55b(c) - The provisions specified in paragraph (a) above does not apply during maintenance and repair of ash conveying systems.

**II. TESTING REQUIREMENTS.**

**# 003 [40 CFR Part 60 Standards of Performance for New Stationary Sources §40 CFR 60.38b]**

**Subpart Cb - Emission Guidelines and Compliance Schedules for Municipal Waste Combustors  
Compliance and performance testing.**

TO THE EXTENT THAT THE CEM PROVISIONS OF GROUP G05 ARE MORE STRINGENT THAN THE CEM PROVISIONS OF THIS CONDITION, COMPLIANCE WITH THE PROVISIONS OF GROUP G05 WILL ASSURE COMPLIANCE WITH THIS CONDITION.

60.38b(a) - The Facility shall comply with all performance testing methods as listed below and stated in §60.58b of subpart Eb of this part, as applicable, except as provided for under §60.24(b)(2) of subpart B of this part and paragraphs (b) and (c) of this section.

60.24(b)(2) - Test methods and procedures for determining compliance with the emission standards shall be specified in the plan. Methods other than those specified in appendix A to this part may be specified in the plan if shown to be equivalent or alternative methods as defined in §60.2 (t) and (u).

60.38b(b) - N/A (The Department's testing schedule for Dioxin/Furans is more stringent)

60.38b(c) - [Reserved]

60.58b(a)(1) - Except as provided by §60.56b, the standards under this subpart apply at all times except during periods of startup, shutdown, and malfunction. Duration of startup, shutdown, or malfunction periods are limited to 3 hours per occurrence, except as provided in paragraph (a)(1)(iii) of this section. During periods of startup, shutdown, or malfunction, monitoring data shall be dismissed or excluded from compliance calculations, but shall be recorded and reported in accordance with the provisions of 40 CFR 60.59b(d)(7).

Note: PER BAT, THE RELIEF PROVISIONS OF THIS SECTION APPLY ONLY TO CO AND NOX AND ONLY DURING THOSE

**SECTION E. Source Group Restrictions.****TIMES OF STARTUP AND SHUTDOWN.**

60.58b(a)(1)(i) - The startup period commences when the affected facility begins the continuous burning of municipal solid waste and does not include any warm up period when the affected facility is combusting fossil fuel or other nonmunicipal solid waste fuel, and no municipal solid waste is being fed to the combustor.

60.58b(a)(1)(ii) - Continuous burning is the continuous, semicontinuous, or batch feeding of municipal solid waste for purposes of waste disposal, energy production, or providing heat to the combustion system in preparation for waste disposal or energy production. The use of municipal solid waste solely to provide thermal protection of the grate or hearth during the startup period when municipal solid waste is not being fed to the grate is not considered to be continuous burning.

60.58b(a)(1)(iii) - For the purpose of compliance with the carbon monoxide emission limits in §60.53b(a), if a loss of boiler water level control (e.g., boiler waterwall tube failure) or a loss of combustion air control (e.g., loss of combustion air fan, induced draft fan, combustion grate bar failure) is determined to be a malfunction, the duration of the malfunction period is limited to 15 hours per occurrence. During such periods of malfunction, monitoring data shall be dismissed or excluded from compliance calculations, but shall be recorded and reported in accordance with the provisions of §60.59b(d)(7).

Note: PER BAT, THIS OPTION IS NOT AVAILABLE.

60.58b(a)(2) - N/A (Facility does not use air curtain incinerators).

**OXYGEN & CARBON DIOXIDE MONITORING**

60.58b(b) - The permittee shall install, calibrate, maintain, and operate a continuous emission monitoring system for measuring the oxygen or carbon dioxide content of the flue gas at each location where carbon monoxide, sulfur dioxide, nitrogen oxides emissions, or particulate matter (if the owner or operator elects to continuously monitor emissions under paragraph (n) of this section) are monitored and record the output of the system and shall comply with the test procedures and test methods specified in paragraphs (b)(1) through (b)(8) of this section.

60.58b(b)(1) - The span value of the oxygen (or 20 percent carbon dioxide) monitor shall be 25 percent oxygen (or 20 percent carbon dioxide).

60.58b(b)(2) - The monitor shall be installed, evaluated, and operated in accordance with §60.13 of subpart A of this part.

60.58b(b)(3) - N/A (The initial performance evaluation has already been completed).

60.58b(b)(4) - The monitor shall conform to Performance Specification 3 in appendix B of this part except for section 2.3 (relative accuracy requirement).

60.58b(b)(5) - The quality assurance procedures of appendix F of this part except for section 5.1.1 (relative accuracy test audit) shall apply to the monitor.

60.58b(b)(6) - If carbon dioxide is selected for use in diluent corrections, the relationship between oxygen and carbon dioxide levels shall be established during the initial performance test according to the procedures and methods specified in paragraphs (b)(6)(i) through (b)(6)(iv) of this section. This relationship may be reestablished during performance compliance tests.

60.58b(b)(6)(i) - The fuel factor equation in Method 3B shall be used to determine the relationship between oxygen and carbon dioxide at a sampling location. Method 3, 3A, or 3B, or as an alternative ASME PTC-19-10-1981-part10, as applicable, shall be used to determine the oxygen concentration at the same location as the carbon dioxide monitor.

60.58b(b)(6)(ii) - Samples shall be taken for at least 30 minutes in each hour.

60.58b(b)(6)(iii) - Each sample shall represent a 1-hour average.

60.58b(b)(6)(iv) - A minimum of three runs shall be performed.

**SECTION E. Source Group Restrictions.**

60.58b(b)(7) - The relationship between carbon dioxide and oxygen concentrations that is established in accordance with paragraph (b)(6) of this section shall be submitted to EPA as part of the initial performance test report and, if applicable, as part of the annual test report if the relationship is reestablished during the annual performance test.

60.58b(b)(8) - During a loss of boiler water level control or loss of combustion air control malfunction period as specified in paragraph (a)(1)(iii) of this section, a diluent cap of 14 percent for oxygen or 5 percent for carbon dioxide may be used in the emissions calculations for sulfur dioxide and nitrogen oxides.

Note: PER BAT, THIS OPTION IS NOT AVAILABLE.

**PARTICULATE AND OPACITY TESTING**

60.58b(c) - Except as provided in paragraph (c)(10) of this section, the procedures and test methods specified in paragraphs (c)(1) through (c)(11) of this section shall be used to determine compliance with the emission limits for particulate matter and opacity under §60.52b(a)(1) and (a)(2).

60.58b(c)(1) - The EPA Reference Method 1 shall be used to select sampling site and number of traverse points.

60.58b(c)(2) - The EPA Reference Method 3, 3A or 3B, or as an alternative ASME PTC-19-10-1981-part10, as applicable, shall be used for gas analysis.

60.58b(c)(3) - EPA Reference Method 5 shall be used for determining compliance with the particulate matter emission limit. The minimum sample volume shall be 1.7 cubic meters. The probe and filter holder heating systems in the sample train shall be set to provide a gas temperature no greater than 160 °C. An oxygen or carbon dioxide measurement shall be obtained simultaneously with each Method 5 run.

60.58b(c)(4) - The owner or operator of an affected facility may request that compliance with the particulate matter emission limit be determined using carbon dioxide measurements corrected to an equivalent of 7 percent oxygen. The relationship between oxygen and carbon dioxide levels for the affected facility shall be established as specified in paragraph (b)(6) of this section.

60.58b(c)(5) - As specified under §60.8 of subpart A of this part, all performance tests shall consist of three test runs. The average of the particulate matter emission concentrations from the three test runs is used to determine compliance.

60.58b(c)(6) - NA (Compliance is demonstrated through the use of COMs)

60.58b(c)(7) - The owner or operator of an affected facility shall conduct an initial performance test for particulate matter emissions and opacity as required under §60.8 of subpart A of this part.

60.58b(c)(8) - The owner or operator of an affected facility shall install, calibrate, maintain, and operate a continuous opacity monitoring system for measuring opacity and shall follow the methods and procedures specified in paragraphs (c)(8)(i) through (c)(8)(iv) of this section.

60.58b(c)(8)(i) - The output of the continuous opacity monitoring system shall be recorded on a 6-minute average basis.

60.58b(c)(8)(ii) - The continuous opacity monitoring system shall be installed, evaluated, and operated in accordance with §60.13 of subpart A of this part.

60.58b(c)(8)(iii) - The continuous opacity monitoring system shall conform to Performance Specification 1 in appendix B of this part.

60.58b(c)(8)(iv) - The initial performance evaluation shall be completed no later than 180 days after the date of the initial startup of the municipal waste combustor unit, as specified under §60.8 of subpart A of this part.

60.58b(c)(9) - Following the date that the initial performance test for particulate matter is completed or is required to be completed under §60.8 of subpart A of this part for an affected facility, the owner or operator shall conduct a performance test for particulate matter on a calendar year basis (no less than 9 calendar months and no more than 15 calendar months

**SECTION E. Source Group Restrictions.**

following the previous performance test; and must complete five performance tests in each 5-year calendar period).

Note: THIS REQUIREMENT IS SUPERCEDED BY THE MORE STRINGENT TEST FREQUENCY REQUIREMENTS IN G01.

60.58b(c)(10) - N/A (Facility does not use continuous monitors for particulate matter).

60.58b(c)(11) - NA (Compliance is demonstrated through the use of COMs)

**CADMIUM, LEAD, AND MERCURY TESTING**

60.58b(d) - The procedures and test methods specified in paragraphs (d)(1) and (d)(2) of this section shall be used to determine compliance with the emission limits for cadmium, lead, and mercury under §60.52b(a).

60.58b(d)(1) - The procedures and test methods specified in paragraphs (d)(1)(i) through (d)(1)(ix) of this section shall be used to determine compliance with the emission limits for cadmium and lead under §60.52b(a) (3) and (4).

60.58b(d)(1)(i) - The EPA Reference Method 1 shall be used for determining the location and number of sampling points.

60.58b(d)(1)(ii) - The EPA Reference Method 3, 3A, or 3B, or as an alternative ASME PTC--19-10-1981-part10, as applicable, shall be used for flue gas analysis.

60.58b(d)(1)(iii) - The EPA Reference Method 29 shall be used for determining compliance with the cadmium and lead emission limits.

60.58b(d)(1)(iv) - An oxygen or carbon dioxide measurement shall be obtained simultaneously with each Method 29 test run for cadmium and lead required under paragraph (d)(1)(iii) of this section.

60.58b(d)(1)(v) - The owner or operator of an affected facility may request that compliance with the cadmium or lead emission limit be determined using carbon dioxide measurements corrected to an equivalent of 7 percent oxygen. The relationship between oxygen and carbon dioxide levels for the affected facility shall be established as specified in paragraph (b)(6) of this section.

60.58b(d)(1)(vi) - All performance tests shall consist of a minimum of three test runs conducted under representative full load operating conditions. The average of the cadmium or lead emission concentrations from three test runs or more shall be used to determine compliance.

60.58b(d)(1)(vii) - Following the date of the initial performance test or the date on which the initial performance test is required to be completed under §60.8 of subpart A of this part, the owner or operator of an affected facility shall conduct a performance test for compliance with the emission limits for cadmium and lead on a calendar year basis (no less than 9 calendar months and no more than 15 calendar months following the previous performance test; and must complete five performance tests in each 5-year calendar period).

Note: THIS REQUIREMENT IS SUPERCEDED BY THE MORE STRINGENT TEST FREQUENCY REQUIREMENTS IN G01.

60.58b(d)(1)(viii)-(ix) - [Reserved]

60.58b(d)(2) - The procedures and test methods specified in paragraphs (d)(2)(i) through (d)(2)(xi) of this section shall be used to determine compliance with the mercury emission limit under §60.52b(a)(5).

60.58b(d)(2)(i) - The EPA Reference Method 1 shall be used for determining the location and number of sampling points.

60.58b(d)(2)(ii) - The EPA Reference Method 3, 3A, or 3B, or as an alternative ASME PTC-19-10-1981-part10, as applicable, shall be used for flue gas analysis.

60.58b(d)(2)(iii) - The EPA Reference Method 29 or as an alternative ASTM D6784-02 shall be used to determine the mercury emission concentration. The minimum sample volume when using Method 29 as an alternative ASTM D6784-02 for mercury shall be 1.7 cubic meters.

**SECTION E. Source Group Restrictions.**

60.58b(d)(2)(iv) - An oxygen (or carbon dioxide) measurement shall be obtained simultaneously with each Method 29 or as an alternative ASTM D6784-02 test run for mercury required under paragraph (d)(2)(iii) of this section.

60.58b(d)(2)(v) - The percent reduction in the potential mercury emissions (%PHg) is computed using equation 1:

$$\% \text{ PHg} = [(E_i - E_o) \div E_i] \times 100 \quad (\text{Eq \#1})$$

where:

%PHg= percent reduction of the potential mercury emissions achieved.

E<sub>i</sub>= potential mercury emission concentration measured at the control device inlet, corrected to 7 percent oxygen (dry basis).

E<sub>o</sub>= controlled mercury emission concentration measured at the mercury control device outlet, corrected to 7 percent oxygen (dry basis).

60.58b(d)(2)(vi) - All performance tests shall consist of a minimum of three test runs conducted under representative full load operating conditions. The average of the mercury emission concentrations or percent reductions from three test runs or more is used to determine compliance.

60.58b(d)(2)(vii) - The owner or operator of an affected facility may request that compliance with the mercury emission limit be determined using carbon dioxide measurements corrected to an equivalent of 7 percent oxygen. The relationship between oxygen and carbon dioxide levels for the affected facility shall be established as specified in paragraph (b)(6) of this section.

60.58b(d)(2)(viii) - The owner or operator of an affected facility shall conduct an initial performance test for mercury emissions as required under §60.8 of subpart A of this part.

60.58b(d)(2)(ix) - Following the date that the initial performance test for mercury is completed or is required to be completed under §60.8 of subpart A of this part, the owner or operator of an affected facility shall conduct a performance test for mercury emissions on a calendar year basis (no less than 9 calendar months and no more than 15 calendar months from the previous performance test; and must complete five performance tests in each 5-year calendar period).

Note: THIS REQUIREMENT IS SUPERCEDED BY THE MORE STRINGENT TEST FREQUENCY REQUIREMENTS IN G01.

60.58b(d)(2)(x) - [Reserved]

60.58b(d)(2)(xi) - The owner or operator of an affected facility where activated carbon injection is used to comply with the mercury emission limit shall follow the procedures specified in paragraph (m) of this section for measuring and calculating carbon usage.

60.58b(d)(3) - N/A (Facility does not use continuous monitors for cadmium and lead).

60.58b(d)(4) - N/A (Facility does not use a continuous automated sampling system for monitoring mercury emissions).

**SULFUR DIOXIDE TESTING**

60.58b(e) - The procedures and test methods specified in paragraphs (e)(1) through (e)(14) of this section shall be used for determining compliance with the sulfur dioxide emission limit under §60.52b(b)(1).

60.58b(e)(1) - The EPA Reference Method 19, section 4.3, shall be used to calculate the daily geometric average sulfur dioxide emission concentration.

60.58b(e)(2) - The EPA Reference Method 19, section 5.4, shall be used to determine the daily geometric average percent reduction in the potential sulfur dioxide emission concentration.

60.58b(e)(3) - The owner or operator of an affected facility may request that compliance with the sulfur dioxide emission limit be determined using carbon dioxide measurements corrected to an equivalent of 7 percent oxygen. The relationship

**SECTION E. Source Group Restrictions.**

between oxygen and carbon dioxide levels for the affected facility shall be established as specified in paragraph (b)(6) of this section.

60.58b(e)(4) - The owner or operator of an affected facility shall conduct an initial performance test for sulfur dioxide emissions as required under §60.8 of subpart A of this part. Compliance with the sulfur dioxide emission limit (concentration or percent reduction) shall be determined by using the continuous emission monitoring system specified in paragraph (e)(5) of this section to measure sulfur dioxide and calculating a 24-hour daily geometric average emission concentration or a 24-hour daily geometric average percent reduction using EPA Reference Method 19, sections 4.3 and 5.4, as applicable.

Note: COMPLIANCE WITH THE MORE STRINGENT AVERAGING TIMES IN G05 WILL CONSTITUTE COMPLIANCE WITH THIS CONDITION.

60.58b(e)(5) - The owner or operator of an affected facility shall install, calibrate, maintain, and operate a continuous emission monitoring system for measuring sulfur dioxide emissions discharged to the atmosphere and record the output of the system.

60.58b(e)(6) - Following the date that the initial performance test for sulfur dioxide is completed or is required to be completed under §60.8 of subpart A of this part, compliance with the sulfur dioxide emission limit shall be determined based on the 24-hour daily geometric average of the hourly arithmetic average emission concentrations using continuous emission monitoring system outlet data if compliance is based on an emission concentration, or continuous emission monitoring system inlet and outlet data if compliance is based on a percent reduction.

60.58b(e)(7) - At a minimum, valid continuous monitoring system hourly averages shall be obtained as specified in paragraphs (e)(7)(i) and (e)(7)(ii) for 90 percent of the operating hours per calendar quarter and 95 percent of the operating days per calendar year that the affected facility is combusting municipal solid waste.

Note: COMPLIANCE WITH THE MORE STRINGENT DATA AVAILABILITY STANDARD IN G05 ENSURES COMPLIANCE WITH THIS SUB-PARAGRAPH.

60.58b(e)(7)(i) - At least two data points per hour shall be used to calculate each 1-hour arithmetic average.

60.58b(e)(7)(ii) - Each sulfur dioxide 1-hour arithmetic average shall be corrected to 7 percent oxygen on an hourly basis using the 1-hour arithmetic average of the oxygen (or carbon dioxide) continuous emission monitoring system data.

60.58b(e)(8) - The 1-hour arithmetic averages required under paragraph (e)(6) of this section shall be expressed in parts per million corrected to 7 percent oxygen (dry basis) and used to calculate the 24-hour daily geometric average emission concentrations and daily geometric average emission percent reductions. The 1-hour arithmetic averages shall be calculated using the data points required under §60.13(e)(2) of subpart A of this part.

60.58b(e)(9) - All valid continuous emission monitoring system data shall be used in calculating average emission concentrations and percent reductions even if the minimum continuous emission monitoring system data requirements of paragraph (e)(7) of this section are not met.

60.58b(e)(10) - The procedures under §60.13 of subpart A of this part shall be followed for installation, evaluation, and operation of the continuous emission monitoring system.

60.58b(e)(11) - The initial performance evaluation shall be completed no later than 180 days after the date of initial startup of the municipal waste combustor as specified under §60.8 of subpart A of this part.

60.58b(e)(12) - The continuous emission monitoring system shall be operated according to Performance Specification 2 in appendix B of this part. For sources that have actual inlet emissions less than 100 parts per million dry volume, the relative accuracy criterion for inlet sulfur dioxide continuous emission monitoring systems should be no greater than 20 percent of the mean value of the reference method test data in terms of the units of the emission standard, or 5 parts per million dry volume absolute value of the mean difference between the reference method and the continuous emission monitoring systems, whichever is greater.

**SECTION E. Source Group Restrictions.**

60.58b(e)(12)(i) - During each relative accuracy test run of the continuous emission monitoring system required by Performance Specification 2 in appendix B of this part, sulfur dioxide and oxygen (or carbon dioxide) data shall be collected concurrently (or within a 30- to 60-minute period) by both the continuous emission monitors and the test methods specified in paragraphs (e)(12)(i)(A) and (e)(12)(i)(B) of this section.

60.58b(e)(12)(i)(A) - For sulfur dioxide, EPA Reference Method 6, 6A, or 6C, or as an alternative ASME PTC-19-10-1981-part10, shall be used.

60.58b(e)(12)(i)(B) - For oxygen (or carbon dioxide), EPA Reference Method 3, 3A, or 3B, or as an alternative ASME PTC-19-10-1981-part10, as applicable, shall be used.

60.58b(e)(12)(ii) - The span value of the continuous emissions monitoring system at the inlet to the sulfur dioxide control device shall be 125 percent of the maximum estimated hourly potential sulfur dioxide emissions of the municipal waste combustor unit. The span value of the continuous emission monitoring system at the outlet of the sulfur dioxide control device shall be 50 percent of the maximum estimated hourly potential sulfur dioxide emissions of the municipal waste combustor unit.

60.58b(e)(13) - Quarterly accuracy determinations and daily calibration drift tests shall be performed in accordance with procedure 1 in appendix F of this part.

60.58b(e)(14) - When sulfur dioxide emissions data are not obtained because of continuous emission monitoring system breakdowns, repairs, calibration checks, and/or zero and span adjustments, emissions data shall be obtained by using other monitoring systems as approved by EPA or EPA Reference Method 19 to provide, as necessary, valid emissions data for a minimum of 90 percent of the hours per calendar quarter and 95 percent of the hours per calendar year that the affected facility is operated and combusting municipal solid waste.

**HYDROGEN CHLORIDE TESTING**

60.58b(f) - The procedures and test methods specified in paragraphs (f)(1) through (f)(8) of this section shall be used for determining compliance with the hydrogen chloride emission limit under

60.58b(f)(1) - The EPA Reference Method 26 or 26A, as applicable, shall be used to determine the hydrogen chloride emission concentration. The minimum sampling time shall be 1 hour.

60.58b(f)(2) - An oxygen (or carbon dioxide) measurement shall be obtained simultaneously with each test run for hydrogen chloride required by paragraph (f)(1) of this section.

60.58b(f)(3) - The percent reduction in potential hydrogen chloride emissions (% PHCl) is computed using equation 2:

$$\%PHCl = \left[ \frac{(E_i - E_o)}{E_i} \right] \times 100$$

where:

%PHCl=percent reduction of the potential hydrogen chloride emissions achieved.

E<sub>i</sub>=potential hydrogen chloride emission concentration measured at the control device inlet, corrected to 7 percent oxygen (dry basis).

E<sub>o</sub>=controlled hydrogen chloride emission concentration measured at the control device outlet, corrected to 7 percent oxygen (dry basis).

60.58b(f)(4) - The owner or operator of an affected facility may request that compliance with the hydrogen chloride emission limit be determined using carbon dioxide measurements corrected to an equivalent of 7 percent oxygen. The relationship between oxygen and carbon dioxide levels for the affected facility shall be established as specified in paragraph (b)(6) of this section.

60.58b(f)(5) - As specified under §60.8 of subpart A of this part, all performance tests shall consist of three test runs. The average of the hydrogen chloride emission concentrations or percent reductions from the three test runs is used to determine compliance.



**SECTION E. Source Group Restrictions.**

60.58b(f)(6) - The owner or operator of an affected facility shall conduct an initial performance test for hydrogen chloride as required under §60.8 of subpart A of this part.

60.58b(f)(7) - Following the date that the initial performance test for hydrogen chloride is completed or is required to be completed under §60.8 of subpart A of this part, the owner or operator of an affected facility shall conduct a performance test for hydrogen chloride emissions on an annual basis (no more than 12 calendar months following the previous performance test).

60.58b(f)(8) - N/A (Provisions of paragraphs (n) and (o) do not apply)

**DIOXIN/FURAN TESTING**

60.58b(g) - The procedures and test methods specified in paragraphs (g)(1) through (g)(9) of this section shall be used to determine compliance with the limits for dioxin/furan emissions under §60.52b(c).

60.58b(g)(1) - The EPA Reference Method 1 shall be used for determining the location and number of sampling points.

60.58b(g)(2) - The EPA Reference Method 3, 3A, or 3B, or as an alternative ASME PTC-19-10-1981-part10, as applicable, shall be used for flue gas analysis.

60.58b(g)(3) - The EPA Reference Method 23 shall be used for determining the dioxin/furan emission concentration.

60.58b(g)(3)(i) - The minimum sample time shall be 4 hours per test run.

60.58b(g)(3)(ii) - An oxygen (or carbon dioxide) measurement shall be obtained simultaneously with each Method 23 test run for dioxins/furans.

60.58b(g)(4) - The owner or operator of an affected facility shall conduct an initial performance test for dioxin/furan emissions in accordance with paragraph (g)(3) of this section, as required under §60.8 of subpart A of this part.

60.58b(g)(5) - Following the date that the initial performance test for dioxins/furans is completed or is required to be completed under §60.8 of subpart A of this part, the owner or operator of an affected facility shall conduct performance tests for dioxin/furan emissions in accordance with paragraph (g)(3) of this section, according to one of the schedules specified in paragraphs (g)(5)(i) through (g)(5)(iii) of this section.

60.58b(g)(5)(i) - For affected facilities, performance tests shall be conducted on a calendar year basis (no less than 9 calendar months and no more than 15 calendar months following the previous performance test; and must complete five performance tests in each 5-year calendar period).

Note: THIS REQUIREMENT IS SUPERCEDED BY THE MORE STRINGENT TEST FREQUENCY REQUIREMENTS IN G01.

60.58b(g)(5)(ii) - For the purpose of evaluating system performance to establish new operating parameter levels, testing new technology or control technologies, diagnostic testing, or related activities for the purpose of improving facility performance or advancing the state-of-the-art for controlling facility emissions, the owner or operator of an affected facility that qualifies for the performance testing schedule specified in paragraph (g)(5)(iii) of this section, may test one unit for dioxin/furan and apply the dioxin/furan operating parameters to similarly designed and equipped units on site by meeting the requirements specified in paragraphs (g)(5)(ii)(A) through (g)(5)(ii)(D) of this section.

60.58b(g)(5)(ii)(A) - Follow the testing schedule established in paragraph (g)(5)(iii) of this section. For example, each year a different affected facility at the municipal waste combustor plant shall be tested, and the affected facilities at the plant shall be tested in sequence (e.g., unit 1, unit 2, unit 3, as applicable).

Note: THIS REQUIREMENT IS SUPERCEDED BY THE MORE STRINGENT TEST FREQUENCY REQUIREMENTS IN G01

60.58b(g)(5)(ii)(B) - Upon meeting the requirements in paragraph (g)(5)(iii) of this section for one affected facility, the owner or operator may elect to apply the average carbon mass feed rate and associated carbon injection system operating parameter levels for dioxin/furan as established in paragraph (m) of this section to similarly designed and equipped units



**SECTION E. Source Group Restrictions.**

on site.

60.58b(g)(5)(ii)(C) - Upon testing each subsequent unit in accordance with the testing schedule established in paragraph (g)(5)(iii) of this section, the dioxin/furan and mercury emissions of the subsequent unit shall not exceed the dioxin/furan and mercury emissions measured in the most recent test of that unit prior to the revised operating parameter levels.

60.58b(g)(5)(ii)(D) - The owner or operator of an affected facility that selects to follow the performance testing schedule specified in paragraph (g)(5)(iii) of this section and apply the carbon injection system operating parameters to similarly designed and equipped units on site shall follow the procedures specified in §60.59b(g)(4) for reporting.

60.58b(g)(5)(iii) - Where all performance tests over a 2-year period indicate that dioxin/furan emissions are less than or equal to 7 nanograms per dry standard cubic meter (total mass) for all affected facilities located within a municipal waste combustor plant, the owner or operator of the municipal waste combustor plant may elect to conduct annual performance tests for one affected facility (i.e., unit) per year at the municipal waste combustor plant. At a minimum, a performance test for dioxin/furan emissions shall be conducted on a calendar year basis (no less than 9 calendar months and no more than 15 months following the previous performance test; and must complete five performance tests in each 5-year calendar period) for one affected facility at the municipal waste combustor plant. Each year a different affected facility at the municipal waste combustor plant shall be tested, and the affected facilities at the plant shall be tested in sequence (e.g., unit 1, unit 2, unit 3, as applicable). If each annual performance test continues to indicate a dioxin/furan emission level less than or equal to 7 nanograms per dry standard cubic meter (total mass), the owner or operator may continue conducting a performance test on only one affected facility per calendar year. If any annual performance test indicates either a dioxin/furan emission level greater than 7 nanograms per dry standard cubic meter (total mass), performance tests shall thereafter be conducted annually on all affected facilities at the plant until and unless all annual performance tests for all affected facilities at the plant over a 2-year period indicate a dioxin/furan emission level less than or equal to 7 nanograms per dry standard cubic meter (total mass).

Note: THIS REQUIREMENT IS SUPERCEDED BY THE MORE STRINGENT TEST FREQUENCY REQUIREMENTS IN G01

60.58b(g)(6) - The owner or operator of an affected facility that selects to follow the performance testing schedule specified in paragraph (g)(5)(iii) of this section shall follow the procedures specified in §60.59b(g)(4) for reporting the selection of this schedule.

60.58b(g)(7) - The owner or operator of an affected facility where activated carbon is used shall follow the procedures specified in paragraph (m) of this section for measuring and calculating the carbon usage rate.

60.58b(g)(8) - The owner or operator of an affected facility may request that compliance with the dioxin/furan emission limit be determined using carbon dioxide measurements corrected to an equivalent of 7 percent oxygen. The relationship between oxygen and carbon dioxide levels for the affected facility shall be established as specified in paragraph (b)(6) of this section.

60.58b(g)(9) - As specified under §60.8 of subpart A of this part, all performance tests shall consist of three test runs. The average of the dioxin/furan emission concentrations from the three test runs is used to determine compliance.

60.58b(g)(10) - N/A (Facility does not use a continuous automated sampling system for monitoring dioxin/furan emissions).

**NITROGEN OXIDE TESTING**

60.58b(h) - The procedures and test methods specified in paragraphs (h)(1) through (h)(12) of this section shall be used to determine compliance with the nitrogen oxides emission limit for affected facilities under §60.52b(d).

60.58b(h)(1) - The EPA Reference Method 19, section 4.1, shall be used for determining the daily arithmetic average nitrogen oxides emission concentration.

60.58b(h)(2) - The owner or operator of an affected facility may request that compliance with the nitrogen oxides emission limit be determined using carbon dioxide measurements corrected to an equivalent of 7 percent oxygen. The relationship between oxygen and carbon dioxide levels for the affected facility shall be established as specified in paragraph (b)(6) of this section.

**SECTION E. Source Group Restrictions.**

60.58b(h)(3) - The owner or operator of an affected facility subject to the nitrogen oxides limit under §60.52b(d) shall conduct an initial performance test for nitrogen oxides as required under §60.8 of subpart A of this part. Compliance with the nitrogen oxides emission limit shall be determined by using the continuous emission monitoring system specified in paragraph (h)(4) of this section for measuring nitrogen oxides and calculating a 24-hour daily arithmetic average emission concentration using EPA Reference Method 19, section 4.1.

60.58b(h)(4) - The owner or operator of an affected facility subject to the nitrogen oxides emission limit under §60.52b(d) shall install, calibrate, maintain, and operate a continuous emission monitoring system for measuring nitrogen oxides discharged to the atmosphere, and record the output of the system.

60.58b(h)(5) - Following the date that the initial performance test for nitrogen oxides is completed or is required to be completed under §60.8 of subpart A of this part, compliance with the emission limit for nitrogen oxides required under §60.52b(d) shall be determined based on the 24-hour daily arithmetic average of the hourly emission concentrations using continuous emission monitoring system outlet data.

60.58b(h)(6) - At a minimum, valid continuous emission monitoring system hourly averages shall be obtained as specified in paragraphs (h)(6)(i) and (h)(6)(ii) of this section for 90 percent of the operating hours per calendar quarter and for 95 percent of the operating hours per calendar year that the affected facility is combusting municipal solid waste.

Note: COMPLIANCE WITH THE MORE STRINGENT DATA AVAILABILITY STANDARD IN G05 ENSURES COMPLIANCE WITH THIS SUB-PARAGRAPH.

60.58b(h)(6)(i) - At least 2 data points per hour shall be used to calculate each 1-hour arithmetic average.

60.58b(h)(6)(ii) - Each nitrogen oxides 1-hour arithmetic average shall be corrected to 7 percent oxygen on an hourly basis using the 1-hour arithmetic average of the oxygen (or carbon dioxide) continuous emission monitoring system data.

60.58b(h)(7) - The 1-hour arithmetic averages required by paragraph (h)(5) of this section shall be expressed in parts per million by volume (dry basis) and used to calculate the 24-hour daily arithmetic average concentrations. The 1-hour arithmetic averages shall be calculated using the data points required under §60.13(e)(2) of subpart A of this part.

60.58b(h)(8) - All valid continuous emission monitoring system data must be used in calculating emission averages even if the minimum continuous emission monitoring system data requirements of paragraph (h)(6) of this section are not met.

60.58b(h)(9) - The procedures under §60.13 of subpart A of this part shall be followed for installation, evaluation, and operation of the continuous emission monitoring system. The initial performance evaluation shall be completed no later than 180 days after the date of initial startup of the municipal waste combustor unit, as specified under §60.8 of subpart A of this part.

60.58b(h)(10) - The owner or operator of an affected facility shall operate the continuous emission monitoring system according to Performance Specification 2 in appendix B of this part and shall follow the procedures and methods specified in paragraphs (h)(10)(i) and (h)(10)(ii) of this section.

60.58b(h)(10)(i) - During each relative accuracy test run of the continuous emission monitoring system required by Performance Specification 2 of appendix B of this part, nitrogen oxides and oxygen (or carbon dioxide) data shall be collected concurrently (or within a 30- to 60-minute period) by both the continuous emission monitors and the test methods specified in paragraphs (h)(10)(i)(A) and (h)(10)(i)(B) of this section.

60.58b(h)(10)(i)(A) - For nitrogen oxides, EPA Reference Method 7, 7A, 7C, 7D, or 7E shall be used.

60.58b(h)(10)(i)(B) - For oxygen (or carbon dioxide), EPA Reference Method 3, 3A, or 3B, or as an alternative ASME PTC-19-10-1981-part10, as applicable, shall be used.

60.58b(h)(10)(ii) - The span value of the continuous emission monitoring system shall be 125 percent of the maximum estimated hourly potential nitrogen oxide emissions of the municipal waste combustor unit.

60.58b(h)(11) - Quarterly accuracy determinations and daily calibration drift tests shall be performed in accordance with

**SECTION E. Source Group Restrictions.**

procedure 1 in appendix F of this part.

60.58b(h)(12) - When nitrogen oxides continuous emission data are not obtained because of continuous emission monitoring system breakdowns, repairs, calibration checks, and zero and span adjustments, emissions data shall be obtained using other monitoring systems as approved by EPA or EPA Reference Method 19 to provide, as necessary, valid emissions data for a minimum of 90 percent of the hours per calendar quarter and 95 percent of the hours per calendar year the unit is operated and combusting municipal solid waste.

**COMPLIANCE WITH OPERATING REQUIREMENTS**

60.58b(i) - The procedures specified in paragraphs (i)(1) through (i)(12) of this section shall be used for determining compliance with the operating requirements under §60.53b.

60.58b(i)(1) - Compliance with the carbon monoxide emission limits in §60.53b(a) shall be determined using a 4-hour block arithmetic average for all types of affected facilities except mass burn rotary waterwall municipal waste combustors and refuse-derived fuel stokers.

60.58b(i)(2) - N/A (Facility does not use mass burn rotary waterwall combustors).

60.58b(i)(3) - The owner or operator of an affected facility shall install, calibrate, maintain, and operate a continuous emission monitoring system for measuring carbon monoxide at the combustor outlet and record the output of the system and shall follow the procedures and methods specified in paragraphs (i)(3)(i) through (i)(3)(iii) of this section.

60.58b(i)(3)(i) - The continuous emission monitoring system shall be operated according to Performance Specification 4A in appendix B of this part.

60.58b(i)(3)(ii) - During each relative accuracy test run of the continuous emission monitoring system required by Performance Specification 4A in appendix B of this part, carbon monoxide and oxygen (or carbon dioxide) data shall be collected concurrently (or within a 30- to 60-minute period) by both the continuous emission monitors and the test methods specified in paragraphs (i)(3)(ii)(A) and (i)(3)(ii)(B) of this section. For affected facilities subject to the 100 parts per million dry volume carbon monoxide standard, the relative accuracy criterion of 5 parts per million dry volume is calculated as the absolute value of the mean difference between the reference method and continuous emission monitoring systems.

60.58b(i)(3)(ii)(A) - For carbon monoxide, EPA Reference Method 10, 10A, or 10B shall be used.

60.58b(i)(3)(ii)(B) - For oxygen (or carbon dioxide), EPA Reference Method 3, 3A, or 3B, or ASME PTC-19-10-1981-part10 (incorporated by reference, see §60.17 of subpart A of this part), as applicable, shall be used.

60.58b(i)(3)(iii) - The span value of the continuous emission monitoring system shall be 125 percent of the maximum estimated hourly potential carbon monoxide emissions of the municipal waste combustor unit.

60.58b(i)(4) - The 4-hour block and 24-hour daily arithmetic averages specified in paragraphs (i)(1) and (i)(2) of this section shall be calculated from 1-hour arithmetic averages expressed in parts per million by volume corrected to 7 percent oxygen (dry basis). The 1-hour arithmetic averages shall be calculated using the data points generated by the continuous emission monitoring system. At least two data points shall be used to calculate each 1-hour arithmetic average.

60.58b(i)(5) - The owner or operator of an affected facility may request that compliance with the carbon monoxide emission limit be determined using carbon dioxide measurements corrected to an equivalent of 7 percent oxygen. The relationship between oxygen and carbon dioxide levels for the affected facility shall be established as specified in paragraph (b)(6) of this section.

60.58b(i)(6) - The procedures specified in paragraphs (i)(6)(i) through (i)(6)(v) of this section shall be used to determine compliance with load level requirements under §60.53b(b).

60.58b(i)(6)(i) - The owner or operator of an affected facility with steam generation capability shall install, calibrate, maintain, and operate a steam flow meter or a feedwater flow meter; measure steam (or feedwater) flow in kilograms per hour (or pounds per hour) on a continuous basis; and record the output of the monitor. Steam (or feedwater) flow shall be calculated

**SECTION E. Source Group Restrictions.**

in 4-hour block arithmetic averages.

60.58b(i)(6)(ii) - The method included in the American Society of Mechanical Engineers Power Test Codes: Test Code for Steam Generating Units, Power Test Code 4.1-1964 (R1991) section 4 (incorporated by reference, see §60.17 of subpart A of this part) shall be used for calculating the steam (or feedwater) flow required under paragraph (i)(6)(i) of this section. The recommendations in American Society of Mechanical Engineers Interim Supplement 19.5 on Instruments and Apparatus: Application, part II of Fluid Meters, 6th edition (1971), chapter 4 (incorporated by reference) see §60.17 of subpart A of this part) shall be followed for design, construction, installation, calibration, and use of nozzles and orifices except as specified in (i)(6)(iii) of this section.

60.58b(i)(6)(iii) - Measurement devices such as flow nozzles and orifices are not required to be recalibrated after they are installed.

60.58b(i)(6)(iv) - All signal conversion elements associated with steam (or feedwater flow) measurements must be calibrated according to the manufacturer's instructions before each dioxin/furan performance test, and at least once per year.

60.58b(i)(7) - To determine compliance with the maximum particulate matter control device temperature requirements under §60.53b(c), the owner or operator of an affected facility shall install, calibrate, maintain, and operate a device for measuring on a continuous basis the temperature of the flue gas stream at the inlet to each particulate matter control device utilized by the affected facility. Temperature shall be calculated in 4-hour block arithmetic averages.

60.58b(i)(8) - The maximum demonstrated municipal waste combustor unit load shall be determined during the initial performance test for dioxins/furans and each subsequent performance test during which compliance with the dioxin/furan emission limit specified in §60.52b(c) is achieved. The maximum demonstrated municipal waste combustor unit load shall be the highest 4-hour arithmetic average load achieved during four consecutive hours during the most recent test during which compliance with the dioxin/furan emission limit was achieved. If a subsequent dioxin/furan performance test is being performed on only one affected facility at the MWC plant, as provided in paragraph (g)(5)(iii) of this section, the owner or operator may elect to apply the same maximum municipal waste combustor unit load from the tested facility for all the similarly designed and operated affected facilities at the MWC plant.

60.58b(i)(9) - For each particulate matter control device employed at the affected facility, the maximum demonstrated particulate matter control device temperature shall be determined during the initial performance test for dioxins/furans and each subsequent performance test during which compliance with the dioxin/furan emission limit specified in §60.52b(c) is achieved. The maximum demonstrated particulate matter control device temperature shall be the highest 4-hour arithmetic average temperature achieved at the particulate matter control device inlet during four consecutive hours during the most recent test during which compliance with the dioxin/furan limit was achieved. If a subsequent dioxin/furan performance test is being performed on only one affected facility at the MWC plant, as provided in paragraph (g)(5)(iii) of this section, the owner or operator may elect to apply the same maximum particulate matter control device temperature from the tested facility for all the similarly designed and operated affected facilities at the MWC plant.

60.58b(i)(10) - At a minimum, valid continuous emission monitoring system hourly averages shall be obtained as specified in paragraphs (i)(10)(i) and (i)(10)(ii) of this section for at least 90 percent of the operating hours per calendar quarter and 95 percent of the operating hours per calendar year that the affected facility is combusting municipal solid waste.

Note: COMPLIANCE WITH THE MORE STRINGENT DATA AVAILABILITY STANDARD IN G05 ENSURES COMPLIANCE WITH THIS SUB-PARAGRAPH.

60.58b(i)(10)(i) - At least two data points per hour shall be used to calculate each 1-hour arithmetic average.

60.58b(i)(10)(ii) - At a minimum, each carbon monoxide 1-hour arithmetic average shall be corrected to 7 percent oxygen on an hourly basis using the 1-hour arithmetic average of the oxygen (or carbon dioxide) continuous emission monitoring system data.

60.58b(i)(11) - All valid continuous emission monitoring system data must be used in calculating the parameters specified under paragraph (i) of this section even if the minimum data requirements of paragraph (i)(10) of this section are not met. When carbon monoxide continuous emission data are not obtained because of continuous emission monitoring system

**SECTION E. Source Group Restrictions.**

breakdowns, repairs, calibration checks, and zero and span adjustments, emissions data shall be obtained using other monitoring systems as approved by EPA or EPA Reference Method 10 to provide, as necessary, the minimum valid emission data.

60.58b(i)(12) - Quarterly accuracy determinations and daily calibration drift tests for the carbon monoxide continuous emission monitoring system shall be performed in accordance with procedure 1 in appendix F of this part.

**COMBUSTOR UNIT CAPACITY**

60.58b(j) - The procedures specified in paragraphs (j)(1) and (j)(2) of this section shall be used for calculating municipal waste combustor unit capacity as defined under §60.51b.

60.58b(j)(1) - For municipal waste combustor units capable of combusting municipal solid waste continuously for a 24-hour period, municipal waste combustor unit capacity shall be calculated based on 24 hours of operation at the maximum charging rate. The maximum charging rate shall be determined as specified in paragraphs (j)(1)(i) and (j)(1)(ii) of this section as applicable.

60.58b(j)(1)(i) - For combustors that are designed based on heat capacity, the maximum charging rate shall be calculated based on the maximum design heat input capacity of the unit and a heating value of 12,800 kilojoules per kilogram for combustors firing refuse-derived fuel and a heating value of 10,500 kilojoules per kilogram for combustors firing municipal solid waste that is not refuse-derived fuel.

60.58b(j)(1)(ii) - For combustors that are not designed based on heat capacity, the maximum charging rate shall be the maximum design charging rate.

60.58b(j)(2) - For batch feed municipal waste combustor units, municipal waste combustor unit capacity shall be calculated as the maximum design amount of municipal solid waste that can be charged per batch multiplied by the maximum number of batches that could be processed in a 24-hour period. The maximum number of batches that could be processed in a 24-hour period is calculated as 24 hours divided by the design number of hours required to process one batch of municipal solid waste, and may include fractional batches (e.g., if one batch requires 16 hours, then 24/16, or 1.5 batches, could be combusted in a 24-hour period). For batch combustors that are designed based on heat capacity, the design heating value of 12,800 kilojoules per kilogram for combustors firing refuse-derived fuel and a heating value of 10,500 kilojoules per kilogram for combustors firing municipal solid waste that is not refuse-derived fuel shall be used in calculating the municipal waste combustor unit capacity in megagrams per day of municipal solid waste.

**FUGITIVE ASH EMISSION LIMIT**

60.58b(k) - The procedures specified in paragraphs (k)(1) through (k)(4) of this section shall be used for determining compliance with the fugitive ash emission limit under §60.55b.

60.58b(k)(1) - The EPA Reference Method 22 shall be used for determining compliance with the fugitive ash emission limit under §60.55b. The minimum observation time shall be a series of three 1-hour observations. The observation period shall include times when the facility is transferring ash from the municipal waste combustor unit to the area where ash is stored or loaded into containers or trucks.

60.58b(k)(2) - The average duration of visible emissions per hour shall be calculated from the three 1-hour observations. The average shall be used to determine compliance with §60.55b.

60.58b(k)(3) - The owner or operator of an affected facility shall conduct an initial performance test for fugitive ash emissions as required under §60.8 of subpart A of this part.

60.58b(k)(4) - Following the date that the initial performance test for fugitive ash emissions is completed or is required to be completed under §60.8 of subpart A of this part for an affected facility, the owner or operator shall conduct a performance test for fugitive ash emissions on an annual basis (no more than 12 calendar months following the previous performance test).

**SECTION E. Source Group Restrictions.**

60.58b(l) - N/A (Facility does not use an air curtain incinerator)

**AVERAGE CARBON MASS FEED RATE**

60.58b(m) - The owner or operator of an affected facility where activated carbon injection is used to comply with the mercury emission limit under §60.52b(a)(5), and/or the dioxin/furan emission limits under §60.52(b)(c), or the dioxin/furan emission level specified in paragraph (g)(5)(iii) of this section shall follow the procedures specified in paragraphs (m)(1) through (m)(4) of this section.

60.58b(m)(1) - During the performance tests for dioxins/furans and mercury, as applicable, the owner or operator shall estimate an average carbon mass feed rate based on carbon injection system operating parameters such as the screw feeder speed, hopper volume, hopper refill frequency, or other parameters appropriate to the feed system being employed, as specified in paragraphs (m)(1)(i) and (m)(1)(ii) of this section.

60.58b(m)(1)(i) - An average carbon mass feed rate in kilograms per hour or pounds per hour shall be estimated during the initial performance test for mercury emissions and each subsequent performance test for mercury emissions.

60.58b(m)(1)(ii) - An average carbon mass feed rate in kilograms per hour or pounds per hour shall be estimated during the initial performance test for dioxin/furan emissions and each subsequent performance test for dioxin/furan emissions. If a subsequent dioxin/furan performance test is being performed on only one affected facility at the MWC plant, as provided in paragraph (g)(5)(iii) of this section, the owner or operator may elect to apply the same estimated average carbon mass feed rate from the tested facility for all the similarly designed and operated affected facilities at the MWC plant.

60.58b(m)(2) - During operation of the affected facility, the carbon injection system operating parameter(s) that are the primary indicator(s) of the carbon mass feed rate (e.g., screw feeder setting) shall be averaged over a block 8-hour period, and the 8-hour block average must equal or exceed the level(s) documented during the performance tests specified under paragraphs (m)(1)(i) and (m)(1)(ii) of this section, except as specified in paragraphs (m)(2)(i) and (m)(2)(ii) of this section.

60.58b(m)(2)(i) - During the annual dioxin/furan or mercury performance test and the 2 weeks preceding the annual dioxin/furan or mercury performance test, no limit is applicable for average mass carbon feed rate if the provisions of paragraph (m)(2)(ii) of this section are met.

60.58b(m)(2)(ii) - The limit for average mass carbon feed rate may be waived in accordance with permission granted by the Administrator for the purpose of evaluating system performance, testing new technology or control technologies, diagnostic testing, or related activities for the purpose of improving facility performance or advancing the state-of-the-art for controlling facility emissions.

60.58b(m)(3) - The owner or operator of an affected facility shall estimate the total carbon usage of the plant (kilograms or pounds) for each calendar quarter by two independent methods, according to the procedures in paragraphs (m)(3)(i) and (m)(3)(ii) of this section.

60.58b(m)(3)(i) - The weight of carbon delivered to the plant.

60.58b(m)(3)(ii) - Estimate the average carbon mass feed rate in kilograms per hour or pounds per hour for each hour of operation for each affected facility based on the parameters specified under paragraph (m)(1) of this section, and sum the results for all affected facilities at the plant for the total number of hours of operation during the calendar quarter.

[60 FR 65415, Dec. 19, 1995, as amended at 62 FR 45120, Aug. 25, 1997]

**# 004 [40 CFR Part 60 Standards of Performance for New Stationary Sources §40 CFR 60.38b]  
 Subpart Cb - Emission Guidelines and Compliance Schedules for Municipal Waste Combustors  
 Compliance and performance testing.**

**CARBON INJECTION SYSTEM OPERATION**

60.58b(m)(4) - Pneumatic injection pressure or other carbon injection system operational indicator shall be used to provide additional verification of proper carbon injection system operation. The operational indicator shall provide an instantaneous visual and/or audible alarm to alert the operator of a potential interruption in the carbon feed that would not normally be

**SECTION E. Source Group Restrictions.**

indicated by direct monitoring of carbon mass feed rate (e.g., continuous weight loss feeder) or monitoring of the carbon system operating parameter(s) that are the indicator(s) of carbon mass feed rate (e.g., screw feeder speed). The carbon injection system operational indicator used to provide additional verification of carbon injection system operation, including basis for selecting the indicator and operator response to the indicator alarm, shall be included in section (e)(6) of the site-specific operating manual required under §60.54b(e) of this subpart.

60.58b(n)(1) thru (n)(14) - N/A (Option not chosen by permittee)

60.58b(o)(1) thru (o)(7) - N/A (Option not chosen by permittee)

60.58b(p) - N/A (Facility does not use continuous automated sampling system for dioxin/furans or mercury).

60.58b(q) - N/A (Facility does not use continuous automated sampling system for dioxin/furans or mercury).

**III. MONITORING REQUIREMENTS.**

No additional monitoring requirements exist except as provided in other sections of this permit including Section B (Title V General Requirements).

**IV. RECORDKEEPING REQUIREMENTS.**

No additional record keeping requirements exist except as provided in other sections of this permit including Section B (Title V General Requirements).

**V. REPORTING REQUIREMENTS.**

**# 005 [40 CFR Part 60 Standards of Performance for New Stationary Sources §40 CFR 60.39b]  
Subpart Cb - Emission Guidelines and Compliance Schedules for Municipal Waste Combustors  
Reporting and recordkeeping guidelines, and compliance schedules.**

60.39b(a) thru (h) - N/A (State Plan Approved).

60.59b(a) thru (c) - N/A (Plan Approval would be required). Facility shall comply with 60.59b(d) thru (o) unless otherwise noted below.

**RECORDKEEPING REQUIREMENTS**

60.59b(d) - The owner or operator of an affected facility subject to the standards under §§60.52b, 60.53b, 60.54b, 60.55b, and 60.57b shall maintain records of the information specified in paragraphs (d)(1) through (d)(15) of this section, as applicable, for each affected facility for a period of at least 5 years.

60.59b(d)(1) - The calendar date of each record.

60.59b(d)(2) - The emission concentrations and parameters measured using continuous monitoring systems as specified under paragraphs (d)(2)(i) and (d)(2)(ii) of this section.

60.59b(d)(2)(i) - The measurements specified in paragraphs (d)(2)(i)(A) through (d)(2)(i)(F) of this section shall be recorded and be available for submittal to the Administrator or review on site by an EPA or State inspector.

60.59b(d)(2)(i)(A) - All 6-minute average opacity levels as specified under §60.58b(c).

60.59b(d)(2)(i)(B) - All 1-hour average sulfur dioxide emission concentrations as specified under §60.58b(e).

60.59b(d)(2)(i)(C) - All 1-hour average nitrogen oxides emission concentrations as specified under §60.58b(h).

60.59b(d)(2)(i)(D) - All 1-hour average carbon monoxide emission concentrations, municipal waste combustor unit load measurements, and particulate matter control device inlet temperatures as specified under §60.58b(i).

60.59b(d)(2)(i)(E) - N/A (Facility does not use continuous monitors for particulate matter, cadmium, lead, or mercury, and does not elect to use HCl CEMs for federal purposes).



**SECTION E. Source Group Restrictions.**

60.59b(d)(2)(ii) - The average concentrations and percent reductions, as applicable, specified in paragraphs (d)(2)(ii)(A) through (d)(2)(ii)(F) of this section shall be computed and recorded, and shall be available for submittal to the Administrator or review on-site by an EPA or State inspector.

60.59b(d)(2)(ii)(A) - All 24-hour daily geometric average sulfur dioxide emission concentrations and all 24-hour daily geometric average percent reductions in sulfur dioxide emissions as specified under §60.58b(e).

60.59b(d)(2)(ii)(B) - All 24-hour daily arithmetic average nitrogen oxides emission concentrations as specified under §60.58b(h).

60.59b(d)(2)(ii)(C) - All 4-hour block or 24-hour daily arithmetic average carbon monoxide emission concentrations, as applicable, as specified under §60.58b(i).

60.59b(d)(2)(ii)(D) - All 4-hour block arithmetic average municipal waste combustor unit load levels and particulate matter control device inlet temperatures as specified under §60.58b(i).

60.59b(d)(2)(ii)(E) - N/A (Facility does not use continuous monitors for particulate matter, cadmium, lead, or mercury, and does not elect to use HCl CEMs for federal purposes).

60.59b(d)(2)(ii)(F) - N/A (Facility does not use continuous automated sampling systems to monitor for mercury or dioxin/furans).

60.59b(d)(3) - Identification of the calendar dates when any of the average emission concentrations, percent reductions, or operating parameters recorded under paragraphs (d)(2)(ii)(A) through (d)(2)(ii)(F) of this section, or the opacity levels recorded under paragraph (d)(2)(i)(A) of this section are above the applicable limits, with reasons for such exceedances and a description of corrective actions taken.

60.59b(d)(4) - For affected facilities that apply activated carbon for mercury or dioxin/furan control, the records specified in paragraphs (d)(4)(i) through (d)(4)(v) of this section.

60.59b(d)(4)(i) - The average carbon mass feed rate (in kilograms per hour or pounds per hour) estimated as required under §60.58b(m)(1)(i) of this section during the initial mercury performance test and all subsequent annual performance tests, with supporting calculations.

60.59b(d)(4)(ii) - The average carbon mass feed rate (in kilograms per hour or pounds per hour) estimated as required under §60.58b(m)(1)(ii) of this section during the initial dioxin/furan performance test and all subsequent annual performance tests, with supporting calculations.

60.59b(d)(4)(iii) - The average carbon mass feed rate (in kilograms per hour or pounds per hour) estimated for each hour of operation as required under §60.58b(m)(3)(ii) of this section, with supporting calculations.

60.59b(d)(4)(iv) - The total carbon usage for each calendar quarter estimated as specified by paragraph 60.58b(m)(3) of this section, with supporting calculations.

60.59b(d)(4)(v) - Carbon injection system operating parameter data for the parameter(s) that are the primary indicator(s) of carbon feed rate (e.g., screw feeder speed).

60.59b(d)(5) - [Reserved]

60.59b(d)(6) - Identification of the calendar dates and times (hours) for which valid hourly data specified in paragraphs (d)(6)(i) through (d)(6)(vi) of this section have not been obtained, or continuous automated sampling systems were not operated as specified in paragraph (d)(6)(vii) of this section, including reasons for not obtaining the data and a description of corrective actions taken.

60.59b(d)(6)(i) - Sulfur dioxide emissions data;

60.59b(d)(6)(ii) - Nitrogen oxides emissions data;



**SECTION E. Source Group Restrictions.**

60.59b(d)(6)(iii) - Carbon monoxide emissions data;

60.59b(d)(6)(iv) - Municipal waste combustor unit load data;

60.59b(d)(6)(v) - Particulate matter control device temperature data; and

60.59b(d)(6)(vi) - N/A (Facility does not use continuous monitors for particulate matter, cadmium, lead, or mercury, and does not elect to use HCl CEMs for federal purposes).

60.59b(d)(6)(vii) - N/A (Facility does not use continuous automated sampling systems for dioxins/furans or mercury).

60.59b(d)(7) - Identification of each occurrence that sulfur dioxide emissions data, nitrogen oxides emissions data, particulate matter emissions data, cadmium emissions data, lead emissions data, mercury emissions data, hydrogen chloride emissions data, or dioxin/furan emissions data (for owners and operators who elect to continuously monitor particulate matter, cadmium, lead, mercury, or hydrogen chloride, or who elect to use continuous automated sampling systems for dioxin/furan or mercury emissions, instead of conducting performance testing using EPA manual test methods) or operational data (i.e., carbon monoxide emissions, unit load, and particulate matter control device temperature) have been excluded from the calculation of average emission concentrations or parameters, and the reasons for excluding the data.

60.59b(d)(8) - The results of daily drift tests and quarterly accuracy determinations for sulfur dioxide, nitrogen oxides, and carbon monoxide continuous emission monitoring systems, as required under appendix F of this part, procedure 1.

60.59b(d)(9) - The test reports documenting the results of the initial performance test and all annual performance tests listed in paragraphs (d)(9)(i) and (d)(9)(ii) of this section shall be recorded along with supporting calculations.

60.59b(d)(9)(i) - The results of the initial performance test and all annual performance tests conducted to determine compliance with the particulate matter, opacity, cadmium, lead, mercury, dioxins/furans, hydrogen chloride, and fugitive ash emission limits.

60.59b(d)(9)(ii) - For the initial dioxin/furan performance test and all subsequent dioxin/furan performance tests recorded under paragraph (d)(9)(i) of this section, the maximum demonstrated municipal waste combustor unit load and maximum demonstrated particulate matter control device temperature (for each particulate matter control device).

60.59b(d)(10) - N/A (Facility does not use continuous monitors or sampling systems for particulate matter, cadmium, lead, mercury, or dioxin/furans, and does not elect to use HCl CEMs for federal purposes).

60.59b(d)(11) - N/A (Does not apply per 60.39b(a)).

60.59b(d)(12) - The records specified in paragraphs (d)(12)(i) through (d)(12)(iv) of this section.

60.59b(d)(12)(i) - Records showing the names of the municipal waste combustor chief facility operator, shift supervisors, and control room operators who have been provisionally certified by the American Society of Mechanical Engineers or an equivalent State-approved certification program as required by §60.54b(a) including the dates of initial and renewal certifications and documentation of current certification.

60.59b(d)(12)(ii) - Records showing the names of the municipal waste combustor chief facility operator, shift supervisors, and control room operators who have been fully certified by the American Society of Mechanical Engineers or an equivalent State-approved certification program as required by §60.54b(b) including the dates of initial and renewal certifications and documentation of current certification.

60.59b(d)(12)(iii) - Records showing the names of the municipal waste combustor chief facility operator, shift supervisors, and control room operators who have completed the EPA municipal waste combustor operator training course or a State-approved equivalent course as required by §60.54b(d) including documentation of training completion.

60.59b(d)(12)(iv) - Records of when a certified operator is temporarily off site. Include two main items:

**SECTION E. Source Group Restrictions.**

60.59b(d)(12)(iv)(A) - If the certified chief facility operator and certified shift supervisor are off site for more than 12 hours, but for 2 weeks or less, and no other certified operator is on site, record the dates that the certified chief facility operator and certified shift supervisor were off site.

60.59b(d)(12)(iv)(B) - When all certified chief facility operators and certified shift supervisors are off site for more than 2 weeks and no other certified operator is on site, keep records of four items:

60.59b(d)(12)(iv)(B)(1) - Time of day that all certified persons are off site.

60.59b(d)(12)(iv)(B)(2) - The conditions that cause those people to be off site.

60.59b(d)(12)(iv)(B)(3) - The corrective actions taken by the owner or operator of the affected facility to ensure a certified chief facility operator or certified shift supervisor is on site as soon as practicable.

60.59b(d)(12)(iv)(B)(4) - Copies of the written reports submitted every 4 weeks that summarize the actions taken by the owner or operator of the affected facility to ensure that a certified chief facility operator or certified shift supervisor will be on site as soon as practicable.

60.59b(d)(13) - Records showing the names of persons who have completed a review of the operating manual as required by §60.54b(f) including the date of the initial review and subsequent annual reviews.

60.59b(d)(14) - For affected facilities that apply activated carbon, identification of the calendar dates when the average carbon mass feed rates recorded under paragraph (d)(4)(iii) of this section were less than either of the hourly carbon feed rates estimated during performance tests for mercury emissions and recorded under paragraphs (d)(4)(i) and (d)(4)(ii) of this section, respectively, with reasons for such feed rates and a description of corrective actions taken. For affected facilities that apply activated carbon, identification of the calendar dates when the average carbon mass feed rates recorded under paragraph (d)(4)(iii) of this section were less than either of the hourly carbon feed rates estimated during performance tests for dioxin/furan emissions and recorded under paragraphs (d)(4)(i) and (d)(4)(ii) of this section, respectively, with reasons for such feed rates and a description of corrective actions taken.

60.59b(d)(15) - For affected facilities that apply activated carbon for mercury or dioxin/furan control, identification of the calendar dates when the carbon injection system operating parameter(s) that are the primary indicator(s) of carbon mass feed rate (e.g., screw feeder speed) recorded under paragraph (d)(4)(v) of this section are below the level(s) estimated during the performance tests as specified in §60.58b(m)(1)(i) and §60.58b(m)(1)(ii) of this section, with reasons for such occurrences and a description of corrective actions taken.

60.59b(e) - N/A (Facility does not use an air curtain incinerator).

**REPORTING REQUIREMENTS**

60.59b(f) - N/A (These provisions would only apply after the submittal of a plan approval).

**ANNUAL REPORT**

60.59b(g) - Following the first year of municipal waste combustor operation, the owner or operator of an affected facility shall submit an annual report that includes the information specified in paragraphs (g)(1) through (g)(5) of this section, as applicable, no later than February 1 of each year following the calendar year in which the data were collected (once the unit is subject to permitting requirements under title V of the Act, the owner or operator of an affected facility must submit these reports semiannually).

60.59b(g)(1) - A summary of data collected for all pollutants and parameters regulated under this subpart, which includes the information specified in paragraphs (g)(1)(i) through (g)(1)(v) of this section.

60.59b(g)(1)(i) - A list of the particulate matter, opacity, cadmium, lead, mercury, dioxins/furans, hydrogen chloride, and fugitive ash emission levels achieved during the performance tests recorded under paragraph (d)(9) of this section.

60.59b(g)(1)(ii) - A list of the highest emission level recorded for sulfur dioxide, nitrogen oxides, carbon monoxide,

**SECTION E. Source Group Restrictions.**

particulate matter, cadmium, lead, mercury, hydrogen chloride, and dioxin/furan (for owners and operators who elect to continuously monitor particulate matter, cadmium, lead, mercury, hydrogen chloride, and dioxin/furan emissions instead of conducting performance testing using EPA manual test methods), municipal waste combustor unit load level, and particulate matter control device inlet temperature based on the data recorded under paragraphs (d)(2)(ii)(A) through (d)(2)(ii)(E) of this section.

60.59b(g)(1)(iii) - List the highest opacity level measured, based on the data recorded under paragraph (d)(2)(i)(A) of this section.

60.59b(g)(1)(iv) - Periods when valid data were not obtained as described in paragraphs (g)(1)(iv)(A) through (g)(1)(iv)(C) of this section.

60.59b(g)(1)(iv)(A) - The total number of hours per calendar quarter and hours per calendar year that valid data for sulfur dioxide, nitrogen oxides, carbon monoxide, municipal waste combustor unit load, or particulate matter control device temperature data were not obtained based on the data recorded under paragraph (d)(6) of this section.

60.59b(g)(1)(iv)(B) - N/A (Facility does not use continuous monitors for particulate matter, cadmium, lead, or mercury, and does not elect to use HCl CEMs for federal purposes).

60.59b(g)(1)(iv)(C) - N/A (Facility does not use continuous automated sampling systems for dioxin/furan or mercury).

60.59b(g)(1)(v) - Periods when valid data were excluded from the calculation of average emission concentrations or parameters as described in paragraphs (g)(1)(v)(A) through (g)(1)(v)(C) of this section.

60.59b(g)(1)(v)(A) - The total number of hours that data for sulfur dioxide, nitrogen oxides, carbon monoxide, municipal waste combustor unit load, and particulate matter control device temperature were excluded from the calculation of average emission concentrations or parameters based on the data recorded under paragraph (d)(7) of this section.

60.59b(g)(1)(v)(B) - N/A (Facility does not use continuous monitors for particulate matter, cadmium, lead, or mercury).

60.59b(g)(1)(v)(C) - N/A (Facility does not use continuous automated sampling systems for dioxin/furan or mercury).

60.59b(g)(2) - The summary of data reported under paragraph (g)(1) of this section shall also provide the types of data specified in paragraphs (g)(1)(i) through (g)(1)(vi) of this section for the calendar year preceding the year being reported, in order to provide the Administrator with a summary of the performance of the affected facility over a 2-year period.

60.59b(g)(3) - The summary of data including the information specified in paragraphs (g)(1) and (g)(2) of this section shall highlight any emission or parameter levels that did not achieve the emission or parameter limits specified under this subpart.

60.59b(g)(4) - A notification of intent to begin the reduced dioxin/furan performance testing schedule specified in §60.58b(g)(5)(iii) of this section during the following calendar year and notification of intent to apply the average carbon mass feed rate and associated carbon injection system operating parameter levels as established in §60.58b(m) to similarly designed and equipped units on site.

60.59b(g)(5) - Documentation of periods when all certified chief facility operators and certified shift supervisors are off site for more than 12 hours.

**SEMI-ANNUAL REPORTS**

60.59b(h) - The owner or operator of an affected facility shall submit a semiannual report that includes the information specified in paragraphs (h)(1) through (h)(5) of this section for any recorded pollutant or parameter that does not comply with the pollutant or parameter limit specified under this subpart, according to the schedule specified under paragraph (h)(6) of this section.

60.59b(h)(1) - The semiannual report shall include information recorded under paragraph (d)(3) of this section for sulfur dioxide, nitrogen oxides, carbon monoxide, particulate matter, cadmium, lead, mercury, hydrogen chloride, dioxin/furan (for

**SECTION E. Source Group Restrictions.**

owners and operators who elect to continuously monitor particulate matter, cadmium, lead, mercury, or hydrogen chloride, or who elect to use continuous automated sampling systems for dioxin/furan or mercury emissions, instead of conducting performance testing using EPA manual test methods) municipal waste combustor unit load level, particulate matter control device inlet temperature, and opacity.

60.59b(h)(2) - For each date recorded as required by paragraph (d)(3) of this section and reported as required by paragraph (h)(1) of this section, the semiannual report shall include the sulfur dioxide, nitrogen oxides, carbon monoxide, municipal waste combustor unit load level, particulate matter control device inlet temperature, or opacity data, as applicable, recorded under paragraphs (d)(2)(ii)(A) through (d)(2)(ii)(D) and (d)(2)(i)(A) of this section, as applicable.

60.59b(h)(3) - If the test reports recorded under paragraph (d)(9) of this section document any particulate matter, opacity, cadmium, lead, mercury, dioxins/furans, hydrogen chloride, and fugitive ash emission levels that were above the applicable pollutant limits, the semiannual report shall include a copy of the test report documenting the emission levels and the corrective actions taken.

60.59b(h)(4) - The semiannual report shall include the information recorded under paragraph (d)(15) of this section for the carbon injection system operating parameter(s) that are the primary indicator(s) of carbon mass feed rate.

60.59b(h)(5) - For each operating date reported as required by paragraph (h)(4) of this section, the semiannual report shall include the carbon feed rate data recorded under paragraph (d)(4)(iii) of this section.

60.59b(h)(6) - Semiannual reports required by paragraph (h) of this section shall be submitted according to the schedule specified in paragraphs (h)(6)(i) and (h)(6)(ii) of this section.

60.59b(h)(6)(i) - If the data reported in accordance with paragraphs (h)(1) through (h)(5) of this section were collected during the first calendar half, then the report shall be submitted by August 1 following the first calendar half.

60.59b(h)(6)(ii) - If the data reported in accordance with paragraphs (h)(1) through (h)(5) of this section were collected during the second calendar half, then the report shall be submitted by February 1 following the second calendar half.

60.59b(i) - N/A (Facility does not use air curtain incinerators).

60.59b(j) - All reports specified under paragraphs (a), (b), (c), (f), (g), (h), and (i) of this section shall be submitted as a paper copy, postmarked on or before the submittal dates specified under these paragraphs, and maintained onsite as a paper copy for a period of 5 years.

Note: The reporting requirements of paragraphs (a), (b), (c) & (f) above would only apply after the submittal of a plan approval. The reporting requirements of paragraph (i) above are not applicable because the facility does not use an air curtain incinerator.

60.59b(k) - All records specified under paragraphs (d) and (e) of this section shall be maintained onsite in either paper copy or computer-readable format, unless an alternative format is approved by the Administrator.

60.59b(l) - If the owner or operator of an affected facility would prefer a different annual or semiannual date for submitting the periodic reports required by paragraphs (g), (h) and (i) of this section, then the dates may be changed by mutual agreement between the owner or operator and the Administrator according to the procedures specified in §60.19(c) of subpart A of this part.

Note: The reporting requirements of paragraph (i) above are not applicable because the facility does not use an air curtain incinerator).

60.59b(m) - N/A (Option not chosen by permittee)

60.59b(n)(1) thru (n)(12) - N/A (Option not chosen by permittee)

60.59b(o) - N/A (Facility does not use continuous automated sampling systems for dioxin/furan or mercury).

**SECTION E. Source Group Restrictions.**

[60 FR 65415, Dec. 19, 1995, as amended at 62 FR 45120, 45125, Aug. 25, 1997; 71 FR 27333, May 10, 2006]

**VI. WORK PRACTICE REQUIREMENTS.**

**# 006 [40 CFR Part 60 Standards of Performance for New Stationary Sources §40 CFR 60.34b]  
Subpart Cb - Emission Guidelines and Compliance Schedules for Municipal Waste Combustors  
Emission guidelines for municipal waste combustor operating practices.**

**Carbon Monoxide Limit**

60.34b(a) - The emission limit for carbon monoxide contained in the gases discharged to the atmosphere from each of the facility's combustors is 100 parts per million by volume, corrected to 7 percent oxygen (dry basis), on a 4-hour block average.

60.34b(b) - Municipal waste combustor operating practices shall be at least as protective as those requirements as listed below and stated in §60.53b(b) and (c) of subpart Eb of this part.

60.53b(b) - The permittee shall not operate the combustors at a load level greater than 110 percent of the maximum demonstrated municipal waste combustor unit load as defined in §60.51b, except as specified in paragraphs (b)(1) and (b)(2) of this section. The averaging time is specified under §60.58b(i).

60.53b(b)(1) - During the annual dioxin/furan or mercury performance test and the 2 weeks preceding the annual dioxin/furan or mercury performance test, no municipal waste combustor unit load limit is applicable if the provisions of paragraph (b)(2) of this section are met.

60.53b(b)(2) - The municipal waste combustor unit load limit may be waived in writing by the Administrator for the purpose of evaluating system performance, testing new technology or control technologies, diagnostic testing, or related activities for the purpose of improving facility performance or advancing the state-of-the-art for controlling facility emissions. The municipal waste combustor unit load limit continues to apply, and remains enforceable, until and unless the Administrator grants the waiver.

60.53b(c) - The permittee shall not operate the combustors at a temperature, measured at the particulate matter control device inlet, exceeding 17 °C above the maximum demonstrated particulate matter control device temperature as defined in §60.51b, except as specified in paragraphs (c)(1) and (c)(2) of this section. The averaging time is specified under §60.58b(i). The requirements specified in this paragraph apply to each particulate matter control device utilized at the affected facility.

60.53b(c)(1) - During the annual dioxin/furan or mercury performance test and the 2 weeks preceding the annual dioxin/furan or mercury performance test, no particulate matter control device temperature limitations are applicable if the provisions of paragraph (b)(2) of this section are met.

60.53b(c)(2) - The particulate matter control device temperature limits may be waived in writing by the Administrator for the purpose of evaluating system performance, testing new technology or control technologies, diagnostic testing, or related activities for the purpose of improving facility performance or advancing the state-of-the-art for controlling facility emissions. The temperature limits continue to apply, and remain enforceable, until and unless the Administrator grants the waiver.

60 FR 65415, Dec. 19, 1995, as amended at 62 FR 45120, 45125, Aug. 25, 1997; 69 FR 42121, July 14, 2004; 71 FR 27333, May 10, 2006]

**# 007 [40 CFR Part 60 Standards of Performance for New Stationary Sources §40 CFR 60.35b]  
Subpart Cb - Emission Guidelines and Compliance Schedules for Municipal Waste Combustors  
Emission guidelines for municipal waste combustor operator training and certification.**

Municipal waste combustor operator training and certification shall be at least as protective as those requirements listed below and stated in §60.54b of subpart Eb of this part. Compliance with these requirements shall be done in accordance with the schedule as specified in §60.39b(c)(4).

60.54b(a) - Each chief facility operator and shift supervisor shall obtain and maintain a current provisional operator

**SECTION E. Source Group Restrictions.**

certification from either the American Society of Mechanical Engineers [QRO-1-1994 (incorporated by reference-see §60.17 of subpart A of this part)] or a State certification program.

60.54b(b) - Each chief facility operator and shift supervisor shall have completed full certification or shall have scheduled a full certification exam with either the American Society of Mechanical Engineers [QRO-1-1994 (incorporated by reference-see §60.17 of subpart A of this part)] or a State certification program.

60.54b(c) - The permittee shall not allow the facility to be operated at any time unless one of the following persons is on duty and at the affected facility: A fully certified chief facility operator, a provisionally certified chief facility operator who is scheduled to take the full certification exam according to the schedule specified in paragraph (b) of this section, a fully certified shift supervisor, or a provisionally certified shift supervisor who is scheduled to take the full certification exam according to the schedule specified in paragraph (b) of this section.

60.54b(c)(1) - The requirements as specified in paragraph (c) of this section shall be in effect at all times.

60.54b(c)(2) - If both the certified chief facility operator and certified shift supervisor are unavailable, a provisionally certified control room operator on site at the municipal waste combustion unit may fulfill the certified operator requirement. Depending on the length of time that a certified chief facility operator and certified shift supervisor are away, the owner or operator of the affected facility must meet one of three criteria:

60.54b(c)(2)(i) - When the certified chief facility operator and certified shift supervisor are both off site for 12 hours or less, and no other certified operator is on site, the provisionally certified control room operator may perform the duties of the certified chief facility operator or certified shift supervisor.

60.54b(c)(2)(ii) - When the certified chief facility operator and certified shift supervisor are off site for more than 12 hours, but for two weeks or less, and no other certified operator is on site, the provisionally certified control room operator may perform the duties of the certified chief facility operator or certified shift supervisor without notice to, or approval by, the Administrator. However, the owner or operator of the affected facility must record the period when the certified chief facility operator and certified shift supervisor are off site and include that information in the annual report as specified under §60.59b(g)(5).

60.54b(c)(2)(iii) - When the certified chief facility operator and certified shift supervisor are off site for more than two weeks, and no other certified operator is on site, the provisionally certified control room operator may perform the duties of the certified chief facility operator or certified shift supervisor without approval by the Administrator. However, the owner or operator of the affected facility must take two actions:

60.54b(c)(2)(iii)(A) - Notify the Administrator in writing. In the notice, state what caused the absence and what actions are being taken by the owner or operator of the facility to ensure that a certified chief facility operator or certified shift supervisor is on site as expeditiously as practicable.

60.54b(c)(2)(iii)(B) - Submit a status report and corrective action summary to the Administrator every four weeks following the initial notification. If the Administrator provides notice that the status report or corrective action summary is disapproved, the municipal waste combustion unit may continue operation for 90 days, but then must cease operation. If corrective actions are taken in the 90-day period such that the Administrator withdraws the disapproval, municipal waste combustion unit operation may continue.

60.54b(c)(3) - A provisionally certified operator who is newly promoted or recently transferred to a shift supervisor position or a chief facility operator position at the municipal waste combustion unit may perform the duties of the certified chief facility operator or certified shift supervisor without notice to, or approval by, the Administrator for up to six months before taking the ASME QRO certification exam.

60.54b(d) - All chief facility operators, shift supervisors, and control room operators at affected facilities must complete the EPA or State municipal waste combustor operator training course.

60.54b(e) - The permittee shall develop and update on a yearly basis a site-specific operating manual that shall, at a minimum, address the elements of municipal waste combustor unit operation specified in paragraphs (e)(1) through (e)(11) of this section.

**SECTION E. Source Group Restrictions.**

- 60.54b(e)(1) - A summary of the applicable standards under this subpart;
- 60.54b(e)(2) - A description of basic combustion theory applicable to a municipal waste combustor unit;
- 60.54b(e)(3) - Procedures for receiving, handling, and feeding municipal solid waste;
- 60.54b(e)(4) - Municipal waste combustor unit startup, shutdown, and malfunction procedures;
- 60.54b(e)(5) - Procedures for maintaining proper combustion air supply levels;
- 60.54b(e)(6) - Procedures for operating the municipal waste combustor unit within the standards established under this subpart;
- 60.54b(e)(7) - Procedures for responding to periodic upset or off-specification conditions;
- 60.54b(e)(8) - Procedures for minimizing particulate matter carryover;
- 60.54b(e)(9) - Procedures for handling ash;
- 60.54b(e)(10) - Procedures for monitoring municipal waste combustor unit emissions; and
- 60.54b(e)(11) - Reporting and recordkeeping procedures.
- 60.54b(f) - The permittee shall establish a training program to review the operating manual according to the schedule specified in paragraphs (f)(1) and (f)(2) of this section with each person who has responsibilities affecting the operation of an affected facility including, but not limited to, chief facility operators, shift supervisors, control room operators, ash handlers, maintenance personnel, and crane/load handlers.
- 60.54b(f)(1) - Each person specified in paragraph (f) of this section shall undergo initial training no later than the date specified in paragraph (f)(1)(i), (f)(1)(ii), or (f)(1)(iii) of this section whichever is later.
- 60.54b(f)(1)(i) - The date 6 months after the date of startup of the affected facility;
- 60.54b(f)(1)(ii) - The date prior to the day the person assumes responsibilities affecting municipal waste combustor unit operation; or
- 60.54b(f)(1)(iii) - December 19, 1996.
- 60.54b(f)(2) - Annually, following the initial review required by paragraph (f)(1) of this section.
- 60.54b(g) - The operating manual required by paragraph (e) of this section shall be kept in a readily accessible location for all persons required to undergo training under paragraph (f) of this section. The operating manual and records of training shall be available for inspection by the EPA or its delegated enforcement agency upon request.
- [60 FR 65415, Dec. 19, 1995, as amended at 62 FR 45120, Aug. 25, 1997]

**VII. ADDITIONAL REQUIREMENTS.**

**# 008 [40 CFR Part 60 Standards of Performance for New Stationary Sources §40 CFR 60.32b]  
Subpart Cb - Emission Guidelines and Compliance Schedules for Municipal Waste Combustors  
Designated facilities.**

60.32b(a) - The designated facility to which these guidelines apply is each municipal waste combustor unit with a combustion capacity greater than 250 tons per day of municipal solid waste for which construction was commenced on or before September 20, 1994. (FACILITY'S CURRENT CAPACITY IS APPROXIMATELY 400 TONS PER DAY PER COMBUSTOR).

[60 FR 65415, Dec. 19, 1995, as amended at 62 FR 45119, 45125, Aug. 25, 1997; 71 FR 27332, May 10, 2006]



**SECTION E. Source Group Restrictions.**

**\*\*\* Permit Shield in Effect. \*\*\***



**SECTION E. Source Group Restrictions.**

Group Name: G05

Group Description: Continuous Emission Monitoring (CEM) Requirements

Sources included in this group

ID	Name
001	MW COMBUSTOR 1
002	MW COMBUSTOR 2
003	MW COMBUSTOR 3

**I. RESTRICTIONS.**

No additional requirements exist except as provided in other sections of this permit including Section B (Title V General Requirements).

**II. TESTING REQUIREMENTS.**

No additional testing requirements exist except as provided in other sections of this permit including Section B (Title V General Requirements).

**III. MONITORING REQUIREMENTS.****# 001 [25 Pa. Code §127.441]****Operating permit terms and conditions.**

[Additional authority for this permit condition is derived from, 40 CFR Part 75, 40 CFR Sections 52.2020, and 25 Pa. Code Sections 139.4, 139.101, & 129.97]

**a. Continuous Emission Monitoring Requirements**

1. The following continuous emission monitoring systems (CEMS) must be installed, approved by the Department, operated and maintained in accordance with the requirements of 25 Pa. Code Chapter 139, Subchapter C (relating to requirements for source monitoring for stationary sources), and the "Submittal and Approval", "Record Keeping and Reporting", and "Quality Assurance" requirements of Revision No. 8 of the Department's Continuous Source Monitoring Manual, 274-0300-001.

For Source: Units No. 1, 2, &amp; 3

Pollutant	Measurement	% O2	Averaging Period	Standard	Basis
NOx	ppm	7.0	24-hr daily average	110 ppm dv	continuously
SO2	ppm	7.0	hourly	30 ppm dv or 90% control	continuously
SO2	ppm	7.0	3-hour block	29 ppm dv or 90% control	continuously
HCL	ppm	7.0	24-hr daily average	25 ppm dv or 95% control	continuously
Opacity	percent	N/A	3-min avg/anytime	10/30	continuously
Opacity	percent	N/A	6-minute average	10	continuously

**SECTION E. Source Group Restrictions.**

Pollutant	Measurement	% O <sub>2</sub>	Averaging Period	Standard	Basis
CO	ppm	7.0	4-hr block average	100 ppm <sub>dv</sub>	continuously
CO <sub>2</sub>	percent	N/A	N/A	N/A	continuously
O <sub>2</sub>	percent	N/A	N/A	N/A	continuously
Steam Flow	lbs/hr	N/A	4-hr block average	110% of maximum demonstrated load	continuously
Baghouse Inlet Temp.	Degrees F	N/A	4-hr block average	17 degrees C above maximum demonstrated temp	continuously
Furnace Temperature	Degrees F	N/A	1-hr block average	1800	continuously

Note 1: Furnace temperature measurement shall be made at the roof top of the combustion zone, and baghouse inlet temperature shall be monitored at the inlet to the fabric filters.

Note 2: Compliance with any subsequently issued revisions to the Continuous Source Monitoring Manual will constitute compliance with the terms of this permit.

Note 3: The SO<sub>2</sub> emission reduction standard as defined in the Table above is based on an 8-hour block average.

**b. Data Availability Standards**

1. The continuous emission monitoring systems (CEMS) for steam flow and baghouse inlet temperatures shall meet the following minimum requirements:

- i In each calendar month, at least 90% of the time periods for which an emission standard or an operational parameter applies, shall be valid as set forth in the Quality Assurance section of Revision No. 8 of the Department's Continuous Source Monitoring Manual, 274-0300-001. or,
- ii In each calendar quarter, at least 95% of the hours shall be valid as set forth in the Quality Assurance section of Revision No. 8 of the Department's Continuous Source Monitoring Manual, 274-0300-001.

Note: Compliance with any subsequently issued revisions to the Continuous Source Monitoring Manual will constitute compliance with the terms of this permit.

2. Carbon monoxide and temperature monitoring systems shall meet the following minimum data availability requirements:

- i. 100% of the data hours shall be valid hours.
- ii. At least 90% of the data required to be collected each hour shall be valid data.

3. Opacity monitoring systems shall meet the following minimum data availability requirement:

- i. At least 95% of the data hours during which the incinerator is operating each day shall be valid hours.

4. Hydrogen chloride, sulfur dioxide, steam load (as specified in 40 CFR Section 60.58b) and nitrogen oxide monitoring systems shall meet the following minimum data availability requirement:

**SECTION E. Source Group Restrictions.**

i. At least 90% of the data hours during which the incinerator is operating each month shall be valid hours.

c. Certification and Testing Requirements

i. Initial Application (Phase I)

Upon promulgation of a monitoring requirement, a proposal containing information as listed in the Phase I section of the Department's Continuous Source Monitoring Manual for the proposed CEMs must be submitted to the Department 180 days prior to the initial startup of a new source and within 180 days of promulgation of a monitoring requirement for an existing source.

ii. Performance Testing (Phase II)

After approval of Phase I, the applicant shall proceed with purchasing, installation, and performance testing. The CEM Section must be advised in writing at least 45 days prior to Performance Specification Testing to provide the opportunity to observe and participate in all testing. A testing protocol, describing all testing procedures and methodology to be used must accompany the notice of testing. Schedule changes must be reported seven days prior to testing except that failed tests may be repeated immediately. Testing as listed in the Phase II section of the Department's Continuous Source Monitoring Manual must be completed for the CEMS[s] no later than 180 days after initial source startup and no later than 60 days after the source achieves normal process capacity. During testing, the source must be operated in a manner that is representative of normal operating conditions. All other notifications and performance specification testing must be conducted in accordance with the Department's Continuous Source Monitoring Manual.

iii. Final Approval (Phase III)

The final report of testing as listed in the Phase III section of the Department's Continuous Source Monitoring Manual must be submitted to the Bureau no later than 60 days after completion of the testing. The owner or operator of the source shall not be issued an operating permit until the CEMs have received Phase III approval, in writing from the Department, when installation of a CEMs is made a condition of the plan approval. Until Phase III Department approval is obtained, operation shall be covered solely under condition of a plan approval.

**IV. RECORDKEEPING REQUIREMENTS.****# 002 [25 Pa. Code §127.441]****Operating permit terms and conditions.**

[Additional authority for this permit condition is derived from 40 CFR Part 75, 40 CFR Sections 52.2020, and 25 Pa. Code Sections 139.101(5) and 139.101(12).]

1. The permittee shall comply with the recordkeeping requirements established in 25 Pa. Code Chapter 139, Subchapter C (relating to requirements for source monitoring for stationary sources), the "Record Keeping and Reporting" requirements in the Department's Continuous Source Monitoring Manual, Revision No. 8, 274-0300-001.

2. Records shall be retained for at least 5 years and shall be made available to the Department upon request.

Note: Compliance with any subsequently issued revision to the Continuous Source Monitoring Manual will constitute compliance with this permit.

**V. REPORTING REQUIREMENTS.****# 003 [25 Pa. Code §127.441]****Operating permit terms and conditions.**

Reporting Requirements:

[Additional authority for this permit condition is derived from, 40 CFR Part 75, 40 CFR Sections 52.2020, and 25 Pa. Code Sections 139.101(1)(iv)4, 139.101(10) & 139.101(12)]

1. The permittee shall submit quarterly reports of continuous emission monitoring to the Department in accordance with the requirements established in 25 Pa. Code Chapter 139, Subchapter C (relating to requirements for source monitoring for stationary sources), the "Record Keeping and Reporting" requirements as established in the Department's Continuous Source Monitoring Manual, Revision No. 8, 274-0300-001.

2. The permittee shall report emissions for all periods of unit operation, including startup, shutdown and malfunction.

**SECTION E. Source Group Restrictions.**

3. Initial quarterly reports following system certification shall be submitted to the Department within 35 days following the date upon which the Department notifies the owner or operator, in writing, of the approval of the continuous source monitoring system for use in determining compliance with applicable emission standards.

4. Subsequent quarterly reports shall be submitted to the Department within 30 days after the end of each quarter.

5. Failure to submit required reports of continuous emission monitoring within the time periods specified in this Condition, shall constitute violations of this Permit, unless approved in advance by the Department in writing.

Note: Compliance with any subsequently issued revision to the Continuous Source Monitoring Manual will constitute compliance with this permit.

**VI. WORK PRACTICE REQUIREMENTS.**

No additional work practice requirements exist except as provided in other sections of this permit including Section B (Title V General Requirements).

**VII. ADDITIONAL REQUIREMENTS.****# 004 [25 Pa. Code §127.441]****Operating permit terms and conditions.**

Quality Assurance Requirements:

[Additional authority for this permit condition is derived from, 40 CFR Part 75, 40 CFR Sections 52.2020, and 25 Pa. Code Sections 139.101(1)(iv), 139.101(2), 139.101(3), 139.101(4), 139.101(6), 139.101(7), 139.101(8), 139.101(12), 139.101(14), and 139.101(15)]

Continuous Emission Monitoring Systems and components must be operated and maintained in accordance with the requirements established in 25 Pa. Code Chapter 139, Subchapter C (relating to requirements for source monitoring for stationary sources), the "Quality Assurance" requirements in the Department's Continuous Source Monitoring Manual, Revision No. 8, 274-0300-001.

Compliance with any subsequently issued revision to the Continuous Source Monitoring Manual will constitute compliance with this permit.

**# 005 [25 Pa. Code §127.441]****Operating permit terms and conditions.**

[25 Pa. Code §127.441(c) & Chapter 139; §§114(a)(3), 504(b) of the CAA] Sampling, Testing and Monitoring Procedures

The permittee shall perform the emissions monitoring analysis procedures or test methods required under an applicable requirement including procedures and methods under Sections 114(a)(3) ( 42 U.S.C.A. §§ 7414 (a)(3)) or 504(b) ( 42 U.S.C.A. §§ 7661c(b)) of the Clean Air Act.

\*\*\* Permit Shield in Effect. \*\*\*

**SECTION E. Source Group Restrictions.**

Group Name: G06

Group Description: MWC RACT 3 Requirements

Sources included in this group

ID	Name
001	MW COMBUSTOR 1
002	MW COMBUSTOR 2
003	MW COMBUSTOR 3

**I. RESTRICTIONS.****Emission Restriction(s).****# 001 [25 Pa. Code §129.112]****Presumptive RACT requirements, RACT emission limitations and petition for alternative compliance schedule**

I. 129.112(f): Each of the above combustors shall comply with the presumptive RACT 3 emission limit of 110 ppmvd NO<sub>x</sub> @ 7% oxygen on a daily average, as per 25 Pa. Code Section 129.112(f), and shall follow the requirements of 25 Pa. Code Section 129.115 in demonstrating compliance with the limit.

II. [REQUIREMENT IS IN THE PAST]

III. 129.115:

(b)... [T]he owner and operator of an air contamination source subject to a NO<sub>x</sub> RACT requirement or RACT emission limitation or VOC RACT requirement or RACT emission limitation, or both, listed in § 129.112 (relating to presumptive RACT requirements, RACT emission limitations and petition for alternative compliance schedule) shall demonstrate compliance with the applicable RACT requirement or RACT emission limitation by performing the following monitoring or testing procedures:...

(3) For a municipal waste combustor with a CEMS, monitoring and testing in accordance with the requirements in Chapter 139, Subchapter C, using a daily average. The daily average will be considered valid if it contains at least 18 valid hourly averages reported at any time during the calendar day as required in the quality assurance section of the continuous source monitoring manual.

(f): The owner and operator of an air contamination source subject to this section and §§ 129.111—129.114 shall keep records to demonstrate compliance with §§ 129.111—129.114 and submit reports to the Department or appropriate approved local air pollution control agency in accordance with the applicable regulations in 25 Pa. Code, Part I, Subpart C, Article III (relating to air resources) and as specified in the operating permit or plan approval for the air contamination source as follows:

(1) The records shall include sufficient data and calculations to demonstrate that the requirements of §§ 129.111—129.114 are met.

(2) Data or information required to determine compliance shall be recorded and maintained in a time frame consistent with the averaging period of the requirement.

(3) The records necessary to determine compliance shall be reported to the Department or appropriate approved local air pollution control agency on a schedule specified in the applicable regulation or as otherwise specified in the operating permit or plan approval for the air contamination source.

(k): The records shall be retained by the owner or operator for 5 years and made available to the Department or appropriate approved local air pollution control agency upon receipt of a written request from the Department or appropriate approved local air pollution control agency.

IV. In installing, operating, and maintaining Low NO<sub>x</sub> (LN) Technology on each of the three combustors, the permittee shall do so in accordance with the manufacturer's specifications and with good operating practices.

V. [REQUIREMENT IS IN THE PAST]

**II. TESTING REQUIREMENTS.**

No additional testing requirements exist except as provided in other sections of this permit including Section B (Title V General Requirements).

**SECTION E. Source Group Restrictions.****III. MONITORING REQUIREMENTS.**

No additional monitoring requirements exist except as provided in other sections of this permit including Section B (Title V General Requirements).

**IV. RECORDKEEPING REQUIREMENTS.**

No additional record keeping requirements exist except as provided in other sections of this permit including Section B (Title V General Requirements).

**V. REPORTING REQUIREMENTS.**

No additional reporting requirements exist except as provided in other sections of this permit including Section B (Title V General Requirements).

**VI. WORK PRACTICE REQUIREMENTS.**

No additional work practice requirements exist except as provided in other sections of this permit including Section B (Title V General Requirements).

**VII. ADDITIONAL REQUIREMENTS.**

No additional requirements exist except as provided in other sections of this permit including Section B (Title V General Requirements).

**\*\*\* Permit Shield in Effect. \*\*\***



**SECTION F. Alternative Operation Requirements.**

No Alternative Operations exist for this Title V facility.



**SECTION G. Emission Restriction Summary.**

No emission restrictions listed in this section of the permit.



**SECTION H. Miscellaneous.**

This permit amendment incorporates those RACT3 requirements from plan approval 36-05013A issued on July 31, 2024, and supercedes operating permit 36-05013 issued on December 13, 2021.

- (a) Group G01 includes the Department's BAT requirements for the three similar combustor units, ID nos. 001, 002 and 003.
- (b) Group G02 includes a hydrated lime silo (ID #004), a pebble lime silo (ID #005), and an activated carbon injection system storage silo (ID #008).
- (c) Group G03 includes the fire pump diesel engine (ID #006) and the emergency generator (ID# 009).
- (d) Group G04 includes the Subpart Cb requirements for the three combustors.
- (e) Group G05 includes the Department's CEM conditions for the three combustors.
- (f) Group G06 includes the presumptive RACT3 requirements for the facility's three combustors.

The following miscellaneous sources do not require any restrictions, work practice standards or testing, monitoring, recordkeeping and reporting requirements.

1. Outside diesel storage tank.
2. Fire protection, first aid equipment
3. Maintenance activities
4. Portable space heaters (kerosene)
5. Portable space heaters (propane)
6. Routine office equipment
7. Water treatment tanks
8. Waste oil tank
9. Ash Handling System
10. Two (2) aboveground propane tanks
11. One (1) gasoline storage tank

**Miscellaneous Notations:**

1. The definition of "Shutdown" shall be interpreted as the point at which the chute to the loading hopper of the combustion train is closed, and a period of 30-minutes has passed to allow waste to be emptied from the throat of the feed chute. The permittee will not be required to adhere to the CO and NO<sub>x</sub> emissions standards during shutdown, as long as the duration of the shutdown does not exceed (3) hours per occurrence, before proceeding to either "process down" or to "normal operations".
2. The selected parameters that define normal operations for CEM reporting purposes are when the dry inlet O<sub>2</sub> is less than or equal to 16.5% and the steam flow is greater than or equal to 35,000 lbs/hr. If any of these conditions are not met, the CEM reports the combustor as "process down" for that minute.



\*\*\*\*\* End of Report \*\*\*\*\*

---